

GE Healthcare
Life Sciences

ÄKTA™ ready

Operating Instructions

Original instructions



Table of Contents

1	Introduction	7
1.1	Important user information	9
1.2	Regulatory information	11
1.3	Associated documentation	14
2	Safety instructions	15
2.1	Safety precautions	16
2.2	Labels	27
2.3	Emergency procedures	30
2.4	Recycling information	34
2.5	Declaration of Hazardous Substances (DoHS)	35
3	System description	38
3.1	Overview	39
3.2	Layout	41
3.3	Flow chart	50
3.4	Equipment	53
3.5	UNICORN control system	57
4	Installation	60
4.1	Included in the delivery	62
4.2	Site requirements	63
4.3	Transport	65
4.4	Unpacking	70
4.5	Positioning the system	71
4.6	Connections	72
5	Starting ÄKTA ready	79
5.1	Start and log on to UNICORN	80
5.2	Start the system	81
6	Flow kit installation	82
6.1	ÄKTA ready flow kits	83
6.2	Unpacking the flow kit	85
6.3	Mounting the flow kit	86
7	ÄKTA ready gradient	101
7.1	ÄKTA ready gradient pump	102
7.2	ÄKTA ready gradient flow section	103
7.3	Calibrate and operate the ÄKTA ready gradient pump	107
8	Component test	111
8.1	Run a component test	112

Table of Contents

8.2	The test report	117
8.3	Troubleshooting a failed component test	120
9	Column installation	125
9.1	Columns	127
9.2	Installing a column	130
9.3	Optional column test	137
9.4	Optional column rinsing	140
9.5	Adding columns to the column list	141
10	Creating a method	142
10.1	The Method Editor	143
10.1.1	<i>Introduction to the Method Editor</i>	144
10.1.2	<i>Method Editor layout</i>	146
10.1.3	<i>Other Method Editor features</i>	148
10.2	An example of using the Method Editor	153
10.2.1	<i>Creating the method and selecting a column</i>	154
10.2.2	<i>Block 1: Opening valves</i>	155
10.2.3	<i>Block 2: Auto-zeroing pressure sensors</i>	157
10.2.4	<i>Block 3: Setting PID parameters</i>	158
10.2.5	<i>Block 4: Filling the flow kit</i>	159
10.2.6	<i>Block 5: Equilibration</i>	161
10.2.7	<i>Block 6: Sample load</i>	162
10.2.8	<i>Block 7: Washing unbound sample</i>	164
10.2.9	<i>Block 8: Elution</i>	165
10.2.10	<i>Block 9: Regeneration</i>	167
10.2.11	<i>Saving the method</i>	168
10.3	Creating a column efficiency test	169
11	Run a method	171
11.1	Final preparations before a run	172
11.2	Starting a run	176
11.3	Viewing and printing results	179
11.4	After the run	181
12	Maintenance	183
12.1	Daily maintenance	185
12.2	Yearly maintenance	188
12.3	Spare parts	194
12.4	Storage	195
13	Troubleshooting	196
14	Reference information	201
14.1	Specifications	202
14.2	Process wetted materials	206

14.3	Chemical resistance	208
14.4	Ordering information	211
14.5	PID control	215
14.6	Checklists	217
14.7	More information	222
	Index	223

1 Introduction

Purpose of the Operating Instructions

The *Operating Instructions* provides you with the instructions needed to handle ÄKTA ready in a safe way.

It also describes the procedures required to operate ÄKTA ready on a day-to-day basis, as well as technical information and instructions for troubleshooting and maintenance.

Prerequisites

In order to operate the system in the way it is intended, the following pre-requisites must be fulfilled:

- You should have a general understanding of how a PC and Microsoft™ Windows™ works.
 - The user must have a working knowledge of UNICORN™ software. Refer to UNICORN *Getting Started* manual for a quick and easy guide to UNICORN. It gives a brief introduction to the software structure and the work flow.
 - The user must be acquainted with the use of general bioprocessing equipment and with handling of biological materials.
 - The user must read and understand [Chapter 2 Safety instructions, on page 15](#).
-

About this chapter

This chapter contains important user information, a description of the intended use of ÄKTA ready, regulatory information, list of associated documentation, definitions of safety notices, etc.

1 Introduction

In this chapter

This chapter contains the following sections:

Section	See page
1.1 Important user information	9
1.2 Regulatory information	11
1.3 Associated documentation	14

1.1 Important user information

Read this before using ÄKTA ready



All users must read the safety instructions in the ÄKTA ready user documentation to fully understand the safe use of ÄKTA ready, before installing, using, or maintaining the system.

Do not operate the ÄKTA ready system in any other way than described in the user documentation. Otherwise, you may be exposed to hazards that can lead to personal injury, and you may cause damage to the equipment.

Safety notices

This user documentation contains WARNINGS, CAUTIONS and NOTICES concerning the safe use of the product. See definitions below.

Warnings



WARNING

WARNING indicates a hazardous situation which, if not avoided, could result in death or serious injury. It is important not to proceed until all stated conditions are met and clearly understood.

Cautions



CAUTION

CAUTION indicates a hazardous situation which, if not avoided, could result in minor or moderate injury. It is important not to proceed until all stated conditions are met and clearly understood.

1 Introduction

1.1 Important user information

Notices



NOTICE

NOTICE indicates instructions that must be followed to avoid damage to the product or other equipment.

Notes and tips

Note: *A note is used to indicate information that is important for trouble-free and optimal use of the product.*

Tip: *A tip contains useful information that can improve or optimize your procedures.*

Typographical conventions

Software items are identified in the text by ***bold italic*** text. A colon separates menu levels, thus ***File:Open*** refers to the ***Open*** command in the ***File*** menu.

Hardware items are identified in the text by **bold** text (e.g., **Power** switch).

1.2 Regulatory information

In this section

This section describes the directives and standards that are fulfilled by ÄKTA ready.

Manufacturing information

The table below summarizes the required manufacturing information. For further information, see the EC Declaration of Conformity document.

Requirement	Content
Name and address of manufacturer	GE Healthcare Bio-Sciences AB, Björkgatan 30, SE-751 84 Uppsala, Sweden

CE Conformity

This product complies with the European directives listed in the table, by fulfilling the corresponding harmonized standards.

A copy of the Declaration of Conformity is available on request.

Directive	Title
2006/42/EC	Machinery Directive (MD)
2006/95/EC	Low Voltage Directive (LVD)
2004/108/EC	Electromagnetic Compatibility (EMC) Directive

CE Marking



The CE marking and the corresponding Declaration of conformity is valid for the instrument when it is:

- used as a stand-alone unit, or
- connected to other CE marked instruments, or
- connected to other products recommended or described in the user documentation, and
- used in the same state as it was delivered from GE Healthcare, except for alterations described in the user documentation.

International standards

This product fulfills the requirements of the following standards:

Standard	Description	Notes
EN/IEC 61010-1, UL 61010-1, CAN/CSA-C22.2 No. 61010-1	Safety requirements for electrical equipment for measurement, control, and laboratory use	EN standard is harmonized with 2006/95/EC
EN 61326-1	EMC emissions and immunity requirements for electrical equipment for measurement, control and laboratory use	Harmonized with 2004/108/EC
EN-ISO 12100	Safety of machinery – General principles for design – Risk assessment and risk reduction	Harmonized with 2006/42/EC
Animal free or in compliance with EMEA 410/01 part 6.4	Animal origin	
FDA CFR 21 § 177.2600 USP class VI, EN 10204 2.1, EN 10204 3.1	Traceability for process wetted and pressure retaining polymers and elastomers	

Regulatory compliance of connected equipment

Any equipment connected to ÄKTA ready should meet the safety requirements of EN 61010-1/IEC 61010-1, or relevant harmonized standards. Within the EU, connected equipment must be CE marked.

Environmental Conformity

Regulation	Title
2011/65/EU	Restriction of Hazardous Substances (RoHS) Directive
2012/19/EU	Waste Electrical and Electronic Equipment (WEEE) Directive
Regulation (EC) No 1907/2006	Registration, Evaluation, Authorization and restriction of Chemicals (REACH)
ACPEIP	Administration on the Control of Pollution Caused by Electronic Information Products, China Restriction of Hazardous Substances (RoHS)

1.3 Associated documentation

Generic documentation

Together with each system, the following manuals are supplied providing information that applies to ÄKTA ready independent of the specific configuration.

Document	Purpose/Contents
<i>ÄKTA ready Operating Instructions</i>	Instructions on how to handle ÄKTA ready in a safe way (this manual).
<i>UNICORN™ User Manual package</i>	Detailed instructions on how to use the UNICORN control system.

Third-party component documentation

Documentation for components produced by a third-party are, if existent, also included in the document package.

Related literature

Document	Product	Code No
<i>ReadyToProcess™ columns</i>	Data file	28-9159-87
<i>ÄKTA ready chromatography system</i>	Data file, including Site Preparation Guide	28-9159-86
Keep your ÄKTA ready operating in peak condition	Preventive Maintenance PM Fact Sheet	28-9980-83
<i>Process chromatography: A guide to optimization, scale-up and validation</i>	Handbook	18-1121-56
<i>Efficiency test of ReadyToProcess columns</i>	Application note	28-9198-21
Ready-to-use fluid management solutions for chromatography systems	Application note	28-9958-79
<i>Purification of a monoclonal antibody using ReadyToProcess columns</i>	Application note	28-9198-56

2 Safety instructions



WARNING

Before installing, operating or maintaining ÄKTA ready, all users must read and understand the entire contents of this chapter to become aware of the hazards involved.

Failure to do this may cause human injury or death, or damage to the equipment.

In this chapter

This chapter contains the following sections:

Section	See page
2.1 Safety precautions	16
2.2 Labels	27
2.3 Emergency procedures	30
2.4 Recycling information	34
2.5 Declaration of Hazardous Substances (DoHS)	35

2.1 Safety precautions

The safety precautions in this section are grouped in the following categories:

- [General precautions, on page 16](#)
- [Flammable liquids and explosive environment, on page 17](#)
- [Personal protection, on page 18](#)
- [Installing and moving, on page 18](#)
- [Operation, on page 21](#)
- [Maintenance, on page 25](#)

General precautions



WARNING

The customer must make sure that all installation, maintenance, operation and inspection is carried out by qualified personnel who are adequately trained, understand and adhere to local regulations and the operating instructions, and have a thorough knowledge of ÄKTA ready and the entire process.



WARNING

Do not operate ÄKTA ready in any other way than described in the ÄKTA ready user documentation.



WARNING

Do not use ÄKTA ready if it is not working properly, or if it has suffered any damage, for example:

- damage to the power cord or its plug
- damage caused by dropping the equipment
- damage caused by splashing liquid onto it



WARNING

Emergency stop. Power failure or pressing the **EMERGENCY STOP** does not automatically depressurize the flow path.



WARNING

Do not use any accessories not supplied or recommended by GE Healthcare.



CAUTION

Waste tubes and containers must be secured and sealed to prevent accidental spillage.



CAUTION

Make sure that the waste container is dimensioned for maximum possible volume when the instrument is left unattended.



NOTICE

Any computer used with the equipment shall comply with IEC 60950 and be installed and used according to the manufacturer's instructions.

Flammable liquids and explosive environment



WARNING

Flammable liquids. ÄKTA ready is **not approved** to handle flammable liquids.



WARNING

Explosive environment. ÄKTA ready is **not approved** for work in a potentially explosive atmosphere, in areas classified as Zone 0 to Zone 2 according to IEC 60079-10 2002. ÄKTA ready does not fulfill the requirements of the ATEX Directive.

Personal protection



WARNING

When using hazardous chemical and biological agents, take all suitable protective measures, such as wearing protective glasses and gloves resistant to the substances used. Follow local and/or national regulations for safe operation and maintenance of ÄKTA ready.



WARNING

Personal Protective Equipment (PPE). Whenever packing, unpacking, transporting or moving ÄKTA ready, wear:

- Protective footwear, preferably with steel lining.
- Working gloves, protecting against sharp edges.
- Protective glasses.

Installing and moving



WARNING

Move transport crates. Make sure that the forklift has capacity to safely lift the crate weight. Make sure that the crate is properly balanced so that it will not accidentally tip when moved.



WARNING

Because of the significant weight of ÄKTA ready, great care must be taken not to cause squeezing or crushing injuries during movement. It is recommended that two persons move the system.



WARNING

Access to power switch and power cord. The power switch must always be easy to access. The power cord must always be easy to disconnect.



WARNING

Protective ground. ÄKTA ready must always be connected to a grounded power outlet.



WARNING

Supply voltage. Make sure that the supply voltage at the wall outlet corresponds to the marking on the instrument, before connecting the power cord.



WARNING

High voltage. The mains cable must only be connected by authorized service personnel. Faulty connection might result in live system parts that can give lethal electric shocks.



WARNING

Installing the computer. The computer should be installed and used according to the instructions provided by the manufacturer of the computer.



WARNING

Do not turn on the **Mains power** switch before all connections are made.



CAUTION

The wheels of ÄKTA ready should be locked during normal use. The wheels should be unlocked only when moving the unit.



CAUTION

Make sure that all tubing, hoses and cables are placed so that the risk for tripping accidents is minimized.

2 Safety instructions

2.1 Safety precautions



CAUTION

ÄKTA ready is designed for indoor use only.



CAUTION

Do not use ÄKTA ready in a dusty atmosphere or close to spraying water.



CAUTION

Make sure that correct air pressure is always maintained. Too high or too low air pressure may be hazardous and may cause erroneous results and leakage.



CAUTION

If the system is re-configured, the system label must be updated accordingly. Use a permanent ink pen, or the stickers supplied with the system.



CAUTION

Do not attempt to lift the system by the handle on the left side of the system cabinet. The handle is for maneuvering the cabinet on the floor, not for lifting.

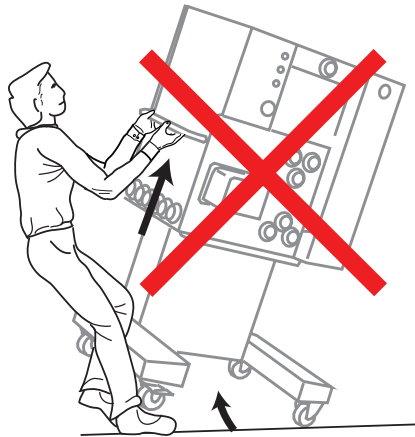

NOTICE

ÄKTA ready shall be installed and prepared by GE Healthcare personnel or third party authorized by GE Healthcare.
Contact GE Healthcare if you require re-installation at a new site.

Operation



WARNING

Operating limits. Never exceed the operating limits stated in this document and on the system label. Operation of ÄKTA ready outside these limits may damage equipment and bodily harm or death may occur.

2 Safety instructions

2.1 Safety precautions



WARNING

Use columns that withstand expected pressures. If not, the columns might rupture, resulting in injury. Preferably use ReadyToProcess columns from GE Healthcare.



WARNING

Never block the outlet tubing with, for instance, stop plugs or any other device causing a pressure build-up, since this will create over-pressure and might result in injury.



WARNING

Never touch the pump or pump lid while the pump is running.



WARNING

High pressure. The flow rate may under no circumstances exceed the specified column maximum flow rate. High flows might affect the packed medium, causing the pressure to exceed the specified column maximum pressure.



WARNING

Never put fingers or any objects other than the intended tubing in the pinch valve opening.



CAUTION

To safely operate ÄKTA ready, knowledge of how to use UNICORN is required. Refer to UNICORN user documentation as required.



CAUTION

Do not insert your fingers or other objects into fans or other moving parts.

**CAUTION**

Ensure that clothing or other equipment does not get caught in the pinch valves.

**CAUTION**

Before use, check that the column is not damaged or otherwise defective. Damaged or defective columns may leak.

**CAUTION**

Do not leave a flow kit mounted on the system for an excessively long time. The tubing walls may stick together where the tubing is squeezed, possibly causing high pressure alarms when running the system.

**NOTICE**

Only use ÄKTA ready flow kits, supplied by GE Healthcare.

**NOTICE**

Excessive temperatures may damage the equipment. Do not run the system at higher temperatures than the specified maximum operation temperature as stated on the system label.

**NOTICE**

Check that the Pressure Control Regulator for the system air supply is set to the pressure stated in the specifications.

2 Safety instructions

2.1 Safety precautions



NOTICE

Keep UV flow cell clean. Do not allow solutions containing dissolved salts, proteins or other solid solutes to dry out in the flow cell. Do not allow particles to enter the flow cell, as damage to the flow cell may occur.



NOTICE

The flow rate may under no circumstances exceed the specified column maximum flow rate. Excessive flow may affect the packed medium, causing the pressure to exceed the specified column maximum pressure. Excessive pressure may also damage the flow kit.



NOTICE

The end of the air trap tubing should be directed away from the operator (preferably, it should be connected to a waste hose).

Chemicals



WARNING

NaOH is corrosive and therefore dangerous to health. When using hazardous chemicals, avoid spillage and wear protective glasses and other suitable Personal Protective Equipment (PPE).



CAUTION

Do not use chemicals with temperatures above the specified limits.



NOTICE

Always make sure that the chromatography media, columns and system components are compatible with NaOH at the concentration, time, and temperatures used.

Maintenance



WARNING

Electrical shock hazard. All installation, service and maintenance of components inside the ÄKTA ready cabinet should be done by service personnel authorized by GE Healthcare. Do not open any covers or replace parts unless specifically stated in the Operating instructions.



WARNING

Only spare parts and accessories that are approved or supplied by GE Healthcare may be used for maintaining or servicing ÄKTA ready.



WARNING

Hazardous chemicals during run. When using hazardous chemicals, run **System CIP** and **Column CIP** to flush the entire system tubing with distilled water, before service and maintenance.



WARNING

Before inspecting and maintaining ÄKTA ready, shut down the system, depressurize it, and disconnect the utilities. If not, accidental pump start-up or unexpected pressure release may cause human injury.



WARNING

Disconnect power. Always disconnect power from the instrument before replacing fuses.



CAUTION

In order to avoid contamination, make sure the system is thoroughly cleaned before changing the flow kit.

2 Safety instructions

2.1 Safety precautions



CAUTION

Connectors on the cabinet, such as connectors for pH, conductivity, network, etc., that are not used, should be plugged to prevent cleaning liquid from entering the connector.



NOTICE

Only use 0.5 M NaOH in the flow kit for a maximum time of 2 hours. Flush the flow kit tubing with a suitable rinsing liquid to remove the NaOH.



NOTICE

Disconnect power. To prevent equipment damage, always disconnect the power from ÄKTA ready before an instrument module is removed or installed, or a cable is connected or disconnected.





2.2 Labels

Introduction

This section describes the various labels on ÄKTA ready and their meaning.





System label

The system label is located on the right side of the leg support of the ÄKTA ready cabinet.



<h1>ÄKTA™ ready</h1>	
Code Number:	<input type="text"/>
System Number:	<input type="text"/>
Manufacturing Year:	<input type="text"/>
Supply Voltage:	100, 120, 200-208, 220-230, 240 V~
Configured For:	<input type="text"/>
Frequency:	50/60 Hz
Max Power Consumption:	1 kVA
Pneumatic Supply:	5,5-7 bar
Protection Class:	IP 45
	
	
 	
<p>GE Healthcare Bio-Sciences AB Björkgatan 30 S-751 84 Uppsala Sweden</p>	

2 Safety instructions

2.2 Labels

Label text	Description
Code Number	Identifies the system as being an ÄKTA ready.
System Number	Identifies the (unique) system installation.
Manufacturing Year	Manufacturing year
Supply Voltage	The voltage alternatives for ÄKTA ready.
Configured For	The voltage the system is currently configured for.
Frequency	Supply voltage frequency
Max Power Consumption	The maximum effect of the system.
Pneumatic Supply	Required pressure for pressurized air supply.
Protection Class	The electrical appliances protection classification according to international standard IEC 60529.
	This symbol indicates that the waste of electrical and electronic equipment must not be disposed as unsorted municipal waste and must be collected separately. Please contact an authorized representative of the manufacturer for information concerning the decommissioning of equipment.
	The system complies with the requirements for electromagnetic compliance (EMC) in Australia and New Zealand.
	The system complies with applicable European directives.
	This symbol indicates that the product contains hazardous materials in excess of the limits established by the Chinese standard SJ/T11363-2006 Requirements for Concentration Limits for Certain Hazardous Substances in Electronics.

Safety labels

Symbol/text	Description
	Warning! Read the user documentation before using ÄKTA ready. Do not open any covers or replace parts unless specifically stated in the user documentation.
	Warning! Pinch hazard. This sign is located next to pinch valves and close to the pump. Never put your fingers or any objects other than the intended tubing in the pinch valve openings. Ensure that clothing or other equipment do not get caught in the pinch valves.
	Warning! Rotating rollers/cogwheels. This sign is located on the pump. Never touch the pump or pump lid while the pump is running. In case of emergency, press the emergency stop button (see Emergency shutdown, on page 31). This immediately stops the pump.

2.3 Emergency procedures

In this section

This section describes how to do an emergency shutdown of ÄKTA ready and the result in the event of power failure.

Precautions



WARNING

Emergency stop. Pressing the **EMERGENCY STOP** will not shut off mains power to the cabinet.



WARNING

Power failure. During a power failure, or if the **EMERGENCY STOP** button is pressed, ÄKTA ready may remain pressurized. Opening a line or vessel at this point could result in the release of potentially hazardous process or cleaning fluid, and cause bodily harm.

When recovering from a power failure or emergency shutdown, make sure all lines and vessels are depressurized before opening.



WARNING

Emergency stop. Power failure or pressing the **EMERGENCY STOP** does not automatically depressurize the flow path.

Emergency shutdown



In a situation where there is a risk of injury, switch off the ongoing run by pressing the **EMERGENCY STOP** on the front of the system cabinet. If required, also switch off the mains power supply.

The **EMERGENCY STOP** immediately stops the pump motor and sets the system in pause mode.

Power failure

The system power is lost if the **Mains power** switch on the cabinet is turned off, the mains cable disconnected or the power supply is lost.

The pump stops if the electrical power to the system is lost. All valves will immediately revert to default positions. Any data that has not been saved at that time may be lost.

If only the system is affected by the power failure and not the computer, UNICORN will display text saying that communication has been broken and that no data are recovered. When power returns to normal, the system will be in **End** state (i.e., it will not resume the run).

A UPS (Uninterrupted Power Supply) protects against temporary power failures by enabling the system to continue to operate for a limited time. A UPS is not included with the system. Contact your local GE Healthcare representative for more information about the options for your specific system.



NOTICE

If the compressed air is lost, all inlet and outlet valves will close and all valves at the system front will open. The pressure is let out via the air trap. There is no risk for the user or the system, but the product may be damaged.

Restart after emergency shut down or power failure

Step	Action
1	Make sure that the condition that caused the power failure or emergency stop is corrected.
2	
	Reset the EMERGENCY STOP button by twisting it clock-wise.
3	Press the PAUSE/CONTINUE button. The system will continue the run with all settings intact.

2.4 Recycling information

Decontamination

ÄKTA ready shall be decontaminated before decommissioning and all local regulations shall be followed with regard to scrapping of the equipment.

Disposal, general instructions

When taking ÄKTA ready out of service, the different materials must be separated and recycled according to national and local environmental regulations.

Flow kits are disposed of according to local regulations regarding potentially dangerous waste.

2.5 Declaration of Hazardous Substances (DoHS)

Introduction

The following product pollution control information is provided according to SJ/T11364-2006 Marking for Control of Pollution caused by Electronic Information Products.

根据SJ/T11364-2006《电子信息产品污染控制标识要求》特提供如下有关污染控制方面的信息

Symbols used in pollution control label

电子信息产品污染控制标志说明

Label	Meaning
	<p>This symbol indicates the product contains hazardous materials in excess of the limits established by the Chinese standard SJ/T11363-2006 Requirements for Concentration Limits for Certain Hazardous Substances in Electronic Information Products. The number in the symbol is the Environment-friendly Use Period (EFUP), which indicates the period during which the toxic or hazardous substances or elements contained in electronic information products will not leak or mutate under normal operating conditions so that the use of such electronic information products will not result in any severe environmental pollution, any bodily injury or damage to any assets. The unit of the period is "Year".</p> <p>In order to maintain the declared EFUP, the product shall be operated normally according to the instructions and environmental conditions as defined in the product manual, and periodic maintenance schedules specified in Product Maintenance Procedures shall be followed strictly.</p> <p>Consumables or certain parts may have their own label with an EFUP value less than the product. Periodic replacement of those consumables or parts to maintain the declared EFUP shall be done in accordance with the Product Maintenance Procedures.</p> <p>This product must not be disposed of as unsorted municipal waste, and must be collected separately and handled properly after decommissioning.</p>

2 Safety instructions

2.5 Declaration of Hazardous Substances (DoHS)

Label	Meaning
	<p>该标志表明本产品含有超过SJ/T11363-2006《电子信息产品中有毒有害物质的限量要求》中限量的有毒有害物质。标志中的数字为本产品的环保使用期，表明本产品在正常使用的条件下，有毒有害物质不会发生外泄或突变，用户使用本产品不会对环境造成严重污染或对其人身、财产造成严重损害的期限。单位为年。</p> <p>为保证所声明的环保使用期限，应按产品手册中所规定的环境条件和方法进行正常使用，并严格遵守产品维修手册中规定的期维修和保养要求。</p> <p>产品中的消耗件和某些零部件可能有其单独的环保使用期限标志，并且其环保使用期限有可能比整个产品本身的环保使用期限短。应到期按产品维修程序更换那些消耗件和零部件，以保证所声明的整个产品的环保使用期限。</p> <p>本产品在使用寿命结束时不可作为普通生活垃圾处理，应被单独收集妥善处理</p>

List of hazardous substances and their concentrations

产品中有毒有害物质或元素的名称及含量

Indication for each major part if substance exceeds limit

Value	Meaning
O	<p>Indicates that this toxic or hazardous substance contained in all of the homogeneous materials for this part is below the limit requirement in SJ/T11363-2006.</p> <p>表示该有毒有害物质在该部件所有均质材料中的含量均在SJ/T11363-2006 标准规定的限量要求以下</p>
X	<p>Indicates that this toxic or hazardous substance contained in at least one of the homogeneous materials used for this part is above the limit requirement in SJ/T11363-2006.</p> <ul style="list-style-type: none">Data listed in the table represents best information available at the time of publication <p>表示该有毒有害物质至少在该部件的某一均质材料中的含量超出 SJ/T11363-2006 标准规定的限量要求</p> <ul style="list-style-type: none">此表所列数据为发布时所能获得的最佳信息

List of hazardous substances

Component name 部件名称	Hazardous substance 有毒有害物质或元素					
	Pb 铅	Hg 汞	Cd 镉	Cr6+ 六价铬	PBB 多溴联苯	PBDE 多溴二苯醚
ÄKTA ready, 29-0320-38 ¹	X	0	0	0	0	0

¹ The product has not been tested as per the Chinese standard SJ/T11363-2006 *Requirements for Concentration Limits for Certain Hazardous Substances in Electronic Information Product*.

3 System description

About this chapter

This chapter provides an overview of the technical properties of ÄKTA ready.

In this chapter

This chapter contains the following sections:

Section	See page
3.1 Overview	39
3.2 Layout	41
3.3 Flow chart	50
3.4 Equipment	53
3.5 UNICORN control system	57

3.1 Overview

Intended use of ÄKTA ready

ÄKTA ready is an isocratic, low pressure, automated liquid chromatography system using ÄKTA ready flow kits (ÄKTA ready Low Flow Kit or ÄKTA ready High Flow Kit) and Ready-ToProcess™ columns up to 20 liter.

The system is based on proven liquid chromatography techniques, such as ion exchange, affinity chromatography, and hydrophobic interaction.

ÄKTA ready is biocompatible and hygienic, and meets all GLP and cGMP demands for Phase I-III in drug development and final-scale production. ÄKTA ready is controlled by the UNICORN software.

ÄKTA ready can be equipped with an extra gradient pump in parallel to the existing pump using ÄKTA ready gradient sections together with ÄKTA ready flow kits and ReadyToProcess™ columns up to 20 liter. More information can be found in [Chapter 7 ÄKTA ready gradient, on page 101](#).

ÄKTA ready is not suitable for operation in a potentially explosive atmosphere or for handling flammable liquids.

Flow kits and columns are ordered separately. See [Section 14.4 Ordering information, on page 211](#) for ordering information and lists of available flow kits and columns.



WARNING

Do not operate ÄKTA ready in any other way than described in the ÄKTA ready user documentation.

Material compliance

All plastic and polymer materials that come in contact with buffers and samples are compliant with USP Class VI, FDA and AFO.

Used materials are traceable back to their production batches.

You can find information about the design and materials used for your unit in the System Documentation.

Chemical resistance is described in [Section 14.3 Chemical resistance, on page 208](#).

3 System description

3.1 Overview

Features

ÄKTA ready features include:

- Liquid flow rates of up to 510 l/h.
 - 4 bar operating pressure.
 - ÄKTA ready flow kits with *Product Documentation*. Animal free origin or equivalent safety certification (EMA/410/01). USP class VI material.
-

Areas of application

ÄKTA ready is designed for process scale-up, and small scale production. Scale-up to production is predictable and trouble-free. In small-scale production, the system can be used to produce purified material for clinical testing programs, or for small-scale production of diagnostic or therapeutic products.



WARNING

Flammable liquids. ÄKTA ready is **not approved** to handle flammable liquids.



WARNING

Explosive environment. ÄKTA ready is **not approved** for work in a potentially explosive atmosphere, in areas classified as Zone 0 to Zone 2 according to IEC 60079-10 2002. ÄKTA ready does not fulfill the requirements of the ATEX Directive.

What is included in the delivery

See [Section 4.1 Included in the delivery, on page 62](#) for a complete list.

Associated products

ÄKTA ready is intended for use with ÄKTA ready flow kits (ÄKTA ready Low Flow Kit or ÄKTA ready High Flow Kit) and ReadyToProcess columns up to 20 l. Flow kits and columns are ordered separately. See [Chapter 14 Reference information, on page 201](#) for ordering information and lists of available flow kits and columns.

3.2 Layout

ÄKTA ready

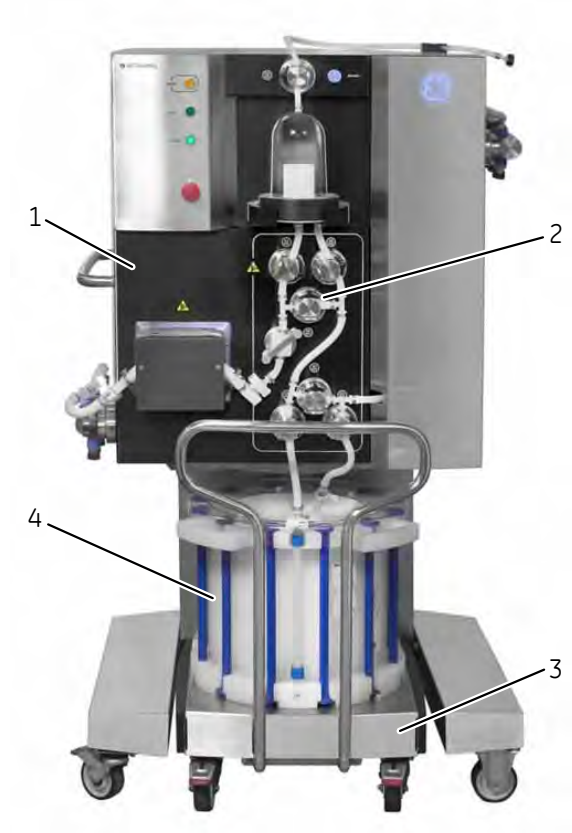

Part	Function
1	ÄKTA ready cabinet unit
2	ÄKTA ready flow kit (ordered separately)
3	Column trolley
4	ReadyToProcess column (ordered separately)

ÄKTA ready gradient

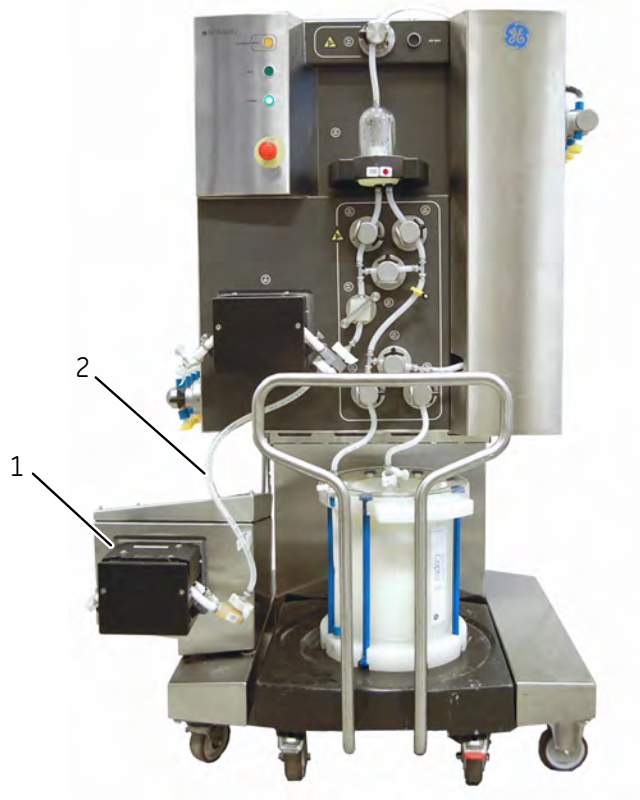

Part	Function
1	ÄKTA ready gradient pump
2	ÄKTA ready gradient flow section

Components on system cabinet – front

The drawing below shows the location of components on the ÄKTA ready cabinet. The cabinet is shown without the cabinet door and with a flow kit mounted. (Components of the flow kit are described in [Flow kit components, on page 47.](#))

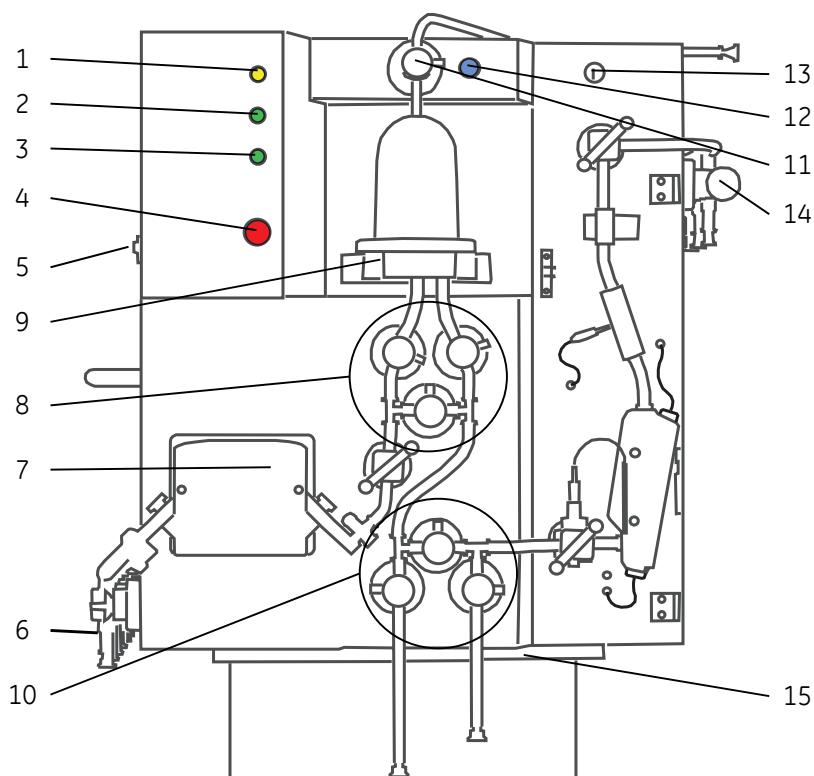

Part	Component	ID tag	Function
1	PAUSE/CONTINUE button and alarm indicator lamp	-	Press button to pause an ongoing process. Press again to continue. (See Pinch valves, on page 53 for valve positions.) Lamp shows steady yellow light during pause. Flashing yellow light indicates UNICORN alarm.
2	RUN indicator lamp	-	Shows green light when system is running. No light when system is idle (i.e., between runs, or during pause).

3 System description

3.2 Layout

Part	Component	ID tag	Function
3	POWER indicator	-	Shows flashing green light during initial communication connection with UNICORN software, when power is switched on. Steady green light when power is on and communication is established.
4	EMERGENCY STOP button		Stops the pump and places the system in pause mode. (See Pinch valves, on page 53 for valve positions.)
5	Mains power switch	-	System mains power switch, located on the left side of the unit.
6	Inlet valves	XV-001 to XV-006	6 valves, located on the left side of the unit.
7	Pump	P-201	<p>A peristaltic pump capable of delivering up to 510 l/h of buffer and sample liquids at a back pressure of up to 4 bar.</p> <p>A peristaltic pump is the simplest type of pump, with no valves or seals that can be clogged or corroded. The liquid is in contact only with the bore of the tubing, eliminating the risk of the pump contaminating the liquid, or the liquid contaminating the pump. Peristaltic pumps can run dry.</p>
8	Air trap valves	XV-021 to XV-023	3-valve arrangement for air trap bypass/in-line.
9	Air trap holder	-	Holder for the flow kit's air trap.
10	Column valves	XV-031 to XV-033	3-valve arrangement for column bypass/in-line.
11	Air trap vent valve	HV-301	Manual valve controlling level in air trap.
12	AIR VENT — Air trap ventilation button	-	Button controlling air trap ventilation through valve HV-301 . Used for releasing excess air from air trap.

Part	Component	ID tag	Function
13	Installation switch	HS-5	<p>Used for releasing and engaging valves during flow kit and column installation. Three different positions:</p> <p>FLOW KIT INSTALL: Opens all valves. User can manually open/close valve locks.</p> <p>RUN: Engages all valves. User cannot open safety valve locks — valves are controlled by UNICORN.</p> <p>COLUMN INSTALL: Releases valves between airtrap outlet to column inlet. Allows for removal of air in tubing between column and air trap.</p>
14	Outlet valves	XV-051 to XV-056	6 valves, located on the right side of the chromatography unit.
15	Air filter	-	The air filter is located in a holder underneath the system cabinet.

Components on system cabinet

— back

Location of connectors

Connectors for system power, pressurized air, customer I/O, and computer network are located on the rear of the system unit, at the bottom of the cabinet:

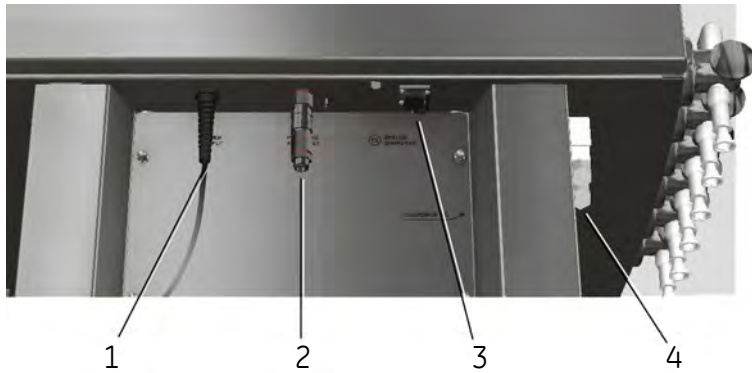

Part	Function
1	POWER SUPPLY , System power cable (cable mounted)
2	PNEUMATIC AIR SUPPLY , Compressed air connector
3	SYSTEM COMPUTER , Ethernet network connector
4	CUSTOMER I/O , User I/O

Instructions for connecting the system

For instructions on how to connect the system, see [Section 4.6 Connections, on page 72](#).

Flow kit components

ÄKTA ready uses flow kits that include all the necessary tubing, from inlet to outlet, including flow cells, air trap, column connection tubing, and pump tubing. Specifications regarding the flow kits, including materials and chemical resistance tables, are found in [Chapter 14 Reference information, on page 201](#). The drawing below shows the components of an ÄKTA ready flow kit.

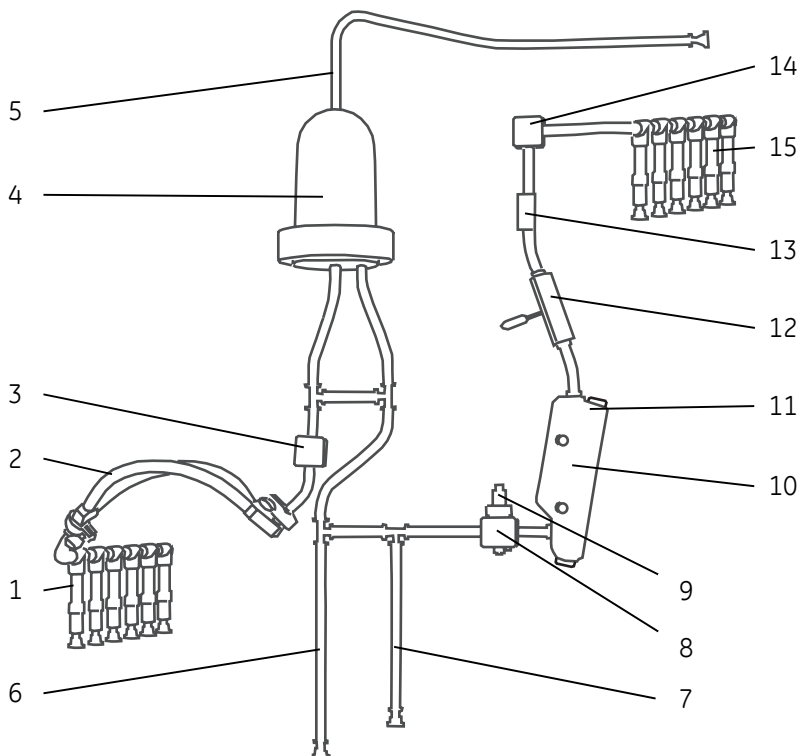

The following table gives a brief description of the flow kit components. Numbers in the table refer to the figure above.

Note: Several flow kit components are flow cells for sensors located on the system cabinet. In such cases, the ID tag technically refers to the sensors rather than the flow cells/adapters. Here, however, the tags are used for identification of both sensors and their corresponding flow cells.

3 System description

3.2 Layout

Part	Component	ID tag	Function
1	Inlet manifold	XV-001 to XV-006	Manifold with 6 inlets corresponding to valves XV-001 to XV-006 . 25 mm TRI-Clamp™ (TC) connectors.
2	Pump tubing	-	Double pump tubing for mounting in the peristaltic pump. Double tubing increases efficiency and reduces pulsation.
3	Flow cell for pressure sensor	PT-111	Flow cell for pressure sensor PT-111 . The sensor measures the pressure after the pump.
4	Air trap	AT-221	Air trap allows for removal of air in buffers and sample. Air trap is filled (air is evacuated) by pressing the AIR VENT button.
5	Air vent tubing	-	Tubing for ventilation of air to/from the air trap. (Manually controlled by the AIR VENT button via valve HV-301 .)
6	Column inlet connector	-	Connector to column inlet tubing. 25 mm TC connector.
7	Column outlet connector	-	Connector to column outlet tubing. 25 mm TC connector.
8	Flow cell for pressure sensor	PT-112	Flow cell for pressure sensor PT-112 . The sensor measures the pressure between pump and column. A pH electrode can be mounted in the flow cell. (A dummy is placed in the electrode holder when flow kit is delivered.)
9	pH electrode (optional)	AE-121	Sensor measuring pH of the liquid. Can be mounted in flow cell for pressure sensor PT-112 . See information about sanitization below table.
10	Flow meter cell	FE-141	Flow cell for flow meter sensor FE-141 , which measures flow using ultrasound.
11	Temperature cell	TE-161	Window for temperature sensor TE-161 . The sensor measures temperature using infrared light. The temperature window is integrated with the flow meter cell.

Part	Component	ID tag	Function
12	Conductivity sensor	CE-101	Sensor measuring the conductivity of the liquid.
13	UV flow cell	AE-131	Flow cell for UV detector AE-131 .
14	Flow cell for pressure sensor	PT-113	Flow cell for safety pressure sensor PT-113 , which measures pressure after the sensors.
15	Outlet manifold	XV-051 to XV-056	Manifold with 6 outlets corresponding to valves XV-051 to XV-056 . 25 mm TC connectors.

Sanitization

Except for the pH electrode, all parts of the flow kit are sanitized at delivery, either through gamma radiation (inlet manifold and main part of flow kit) or autoclaving (pump tubing).

The pH electrode should be sanitized by the user.

3.3 Flow chart

Chart and components

The liquid flow through ÄKTA ready is illustrated in the chart below.

(Black: standard components; Red: optional components)

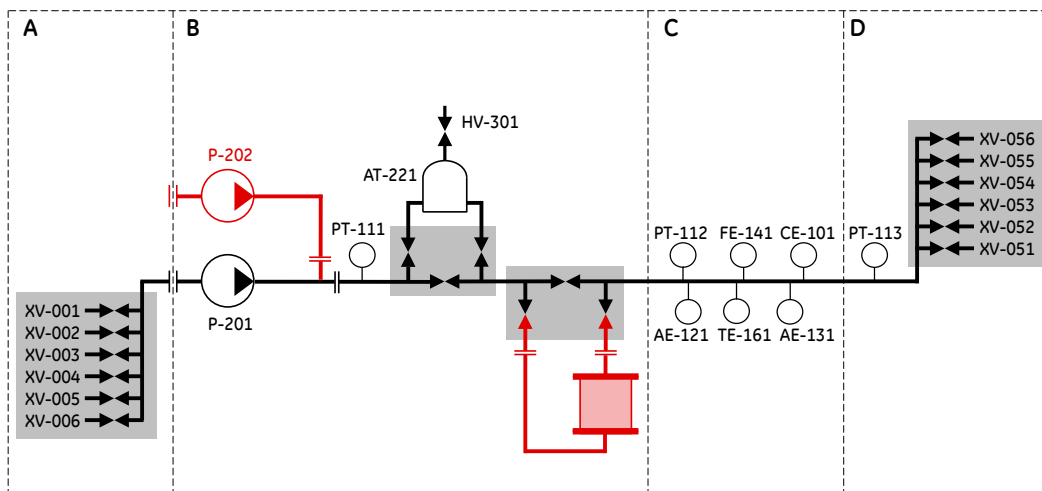

The table below specifies the maximum operating pressure the flow path could be pressurized to with the pressure upgrade strategy in the different parts of the system.

Part	Description	Pressure
A	Low pressure, over the Inlet Manifold	0.6 bar
B	High pressure, over the air trap manifold and column	5.0 bar
C	Medium pressure	2.0 bar
D	Medium pressure, over the outlet manifold	0.95 bar

The table below describes the system components shown in the flow chart.

Part	Function
XV-001 to XV-006	Inlet 1 to 6, grouped in Inlet Manifold

Part	Function
XV-051 to XV-056	Outlet 1 to 6, grouped in Outlet Manifold
PT-111 to PT-113	3 Pressure sensors cells
AE-121	pH electrode (optional)
FE-141	Flow meter cell
TE-161	Temperature sensor
CE-101	Conductivity sensor
AE-131	UV cell
AT-221	Air trap
HV-301	Air vent valve
P-201	System pump
P-202	Gradient pump (optional)

See [Section 3.4 Equipment, on page 53](#) for more information about the parts in the table above.

Note: *The gradient pump (P202) is described in [Chapter 7 ÄKTA ready gradient, on page 101](#).*

From inlet to column

Stage	Description
1	Inlet valves open the appropriate inlet (XV-001 to XV-006 in chart) for sample or buffer.
2	The system pump (P-201) and the gradient pump (P-202) deliver the liquid to the column via a pressure sensor cell (PT-111) and, if preferred, via the air trap (AT-221), where air in the liquid is removed.
3	There are two sets of valves between the pump and the column: <ul style="list-style-type: none"> the air trap manifold, which allows for bypassing the air trap, and the column manifold, which allows for bypassing the column.

From column to outlet

Stage	Description
1	Downstream of the column, the liquid passes through a second pressure sensor cell (PT-112), which has an integrated flow cell for a pH electrode (AE-121).
2	The liquid then continues through: <ul style="list-style-type: none">• a flow meter cell (FE-141) with integrated temperature sensor (TE-161),• a conductivity cell (CE-101), and• a UV cell (AE-131).
3	The last sensor in the path is a third pressure sensor (PT-113).
4	Downstream from the sensors, the liquid continues via the outlet tubing to the outlet manifold, where valves (XV-051 to XV-056) divert the liquid to either waste or fraction collection.

Maximum pressures

- At the outlet manifold, the system works under a pressure of max 0.95 bar.
- Between pump and column the pressure is max 5 bar.
- Between column and outlet manifold the pressure is max 2 bar.
- The different pressure zones are monitored by pressure sensors **PT-111** to **PT-113**.

3.4 Equipment

Pinch valves

Pinch valves are used to control the path of the liquid flow through the system. There are 19 pinch valves in total. The valves have manually operated safety locks keeping the tubing in place and preventing the valves from accidentally closing during flow kit installation.



WARNING

Never put fingers or any objects other than the intended tubing in the pinch valve opening.

Valves	Default position
Inlet valves, XV-001 to XV-006	Closed
Air trap valves, XV-021 to XV-023	Inline
Column valves, XV-031 to XV-033	Bypass
Outlet valves, XV-051 to XV-056	Closed
Air Vent Valve, HV-301	Closed

During pause, the air trap valves will remain in the same position as during the run. The user can change this by setting the air trap valves to inline during pause, in the **System Settings** in UNICORN.

Pressure cells

The pressure cells in the ÄKTA ready flow kits are designed with a flexible membrane that is brought into contact with a transducer (load cell) on the system cabinet for measurement of fluid pressure.

There are three pressure cells, continuously measuring the pressure of the liquid:

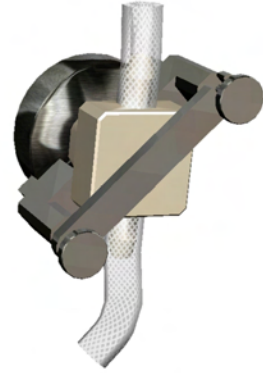

Pressure cell	Location	Function
PT-111	The first pressure cell is located in the high pressure flow path, directly downstream from the system pump.	Measures the total pressure over the entire flow path.
PT-112	The second is located in the medium pressure flow path, downstream from the column.	Measures the total pressure in the flow path after the column. The difference between pressures at PT-111 and PT-112 is the pressure drop (Delta p) over the column and the packed bed.
PT-113	The third is located in the low pressure flow path, upstream from the outlet manifold.	Pressure sensor PT-113 protects the low pressure outlet manifold from overpressure, caused by failure in the fluid lines outside the system (e.g., pinched outlet tubing or overfilled bag at outlet).

pH electrode (optional)

The pH electrode, **AE-121**, is an optional accessory (see [Section 14.4 Ordering information, on page 211](#)). The electrode can be mounted in a holder on top of pressure cell **PT-112**. When a flow kit is delivered, a dummy is located in the pH electrode holder. Unlike the rest of the flow kit, the pH electrode has not been autoclaved or subjected to gamma radiation at delivery and must therefore be cleaned by the user.

The pH electrode should be calibrated at least once a day (see [pH calibration, on page 187](#)).

Flow meter cell

The flow meter cell, **FE-141**, is placed after the pressure cell **PT-112**/pH electrode **AE-121** in the flow path. The flow meter measures the liquid velocity using ultrasound. Transducers are connected to both sides of a straight channel through the cell. The difference between upstream and downstream ultrasound velocity is measured and the result is used to compute the flow. In order to ensure proper transmission of the sound energy, the contact surfaces should be coated with a thin layer of Vaseline™ delivered with the flow kit or similar lubricant before the transducers are connected.

Air sensor

The air sensors, **AE-151** and **AE-152**, are high precision monitors designed for continuous monitoring of air bubbles in the flow path. When air is detected, the system is either paused, or performs an action that is set in the method.

Temperature sensor

The temperature sensor, **TE-161**, is located on the front of the system cabinet, beneath the flow meter cell. The sensor measures the infrared radiation emitted from a dedicated measurement window in the body of the flow meter cell. A lens in front of the sensor focuses the infrared radiation.

Note: *A system that is not properly temperature equilibrated may produce incorrect temperature readings. Therefore, if the system or flow kit is moved between rooms with different temperatures, time must be allowed for the equipment to adjust to the new ambient temperature. In particular, the body of the flow meter cell may need several hours to adjust to room temperature.*

3 System description

3.4 Equipment

Conductivity sensor

The conductivity sensor, **CE-101**, is included with the flow kit (for all other sensors, the flow kit includes only the flow cells). The conductivity sensor is located after the flow meter cell in the flow path. It is primarily used to verify the conductivity of buffer solutions. Conductivity measurement is temperature compensated and thus dependent on correct temperature readings. The conductivity sensor cable is connected to the system cabinet using a screw-on connector secured by a fastening nut. The standard setting of the cell constant is 12.5 cm^{-1} .

UV cell

The UV cell, **AE-131**, is located after the conductivity cell in the flow path. The cell consists of a transparent rectangular flow cell. The cell is mounted in a holder containing a UV LED emitting at 280 nm and two detectors measuring the UV absorbance of the liquid. For correct measurements it is important that UV cell and sensor windows are properly fitted, kept clean and dry. The temperature of the process liquid must not be lower than 10°C from the ambient temperature. Otherwise there is a risk for condensation of moisture on the flow cell window.

3.5 UNICORN control system

Overview

ÄKTA ready is controlled by UNICORN process control software.

UNICORN can save established processes as methods. The methods include the instructions necessary for process operation and documentation.

UNICORN includes a comprehensive system of user access levels to be programmed limiting the operations a given user may perform on ÄKTA ready. To secure safe operation of the system, you should limit access to the system to those qualified and trained in its operation.

The UNICORN software wizards and the UNICORN User Manual provide complete instructions for programming and for using the software for process control.

System operators are responsible for designing methods which conform to standard operating procedures and Good Manufacturing Practice procedures.

UNICORN is compliant with FDA 21 CFR Part 11.

Knowledge prerequisite

At least basic knowledge of UNICORN is expected to operate ÄKTA ready safely.

Information on how to use UNICORN can be obtained from the UNICORN User Manuals and available tutorials. This manual does not cover how to use UNICORN.

Contact your local GE Healthcare representative for advice if required.

System networks

UNICORN can be installed on a stand-alone computer to control one to four locally attached systems. However, the computer can only show one system at a time. Multiple computers can view the output data from one system. UNICORN can also be installed on a network.

Software modules

The UNICORN control software consists of four modules:

Module	Function
UNICORN Manager/Administration	File handling and administration tasks; for example, definition of systems and managing user profiles.
Method Editor	Method creation and editing for preprogrammed control of ÄKTA ready.
System Control	Process online control and monitoring using pre-defined methods or manual control.
Evaluation	Evaluation and presentation of stored results.

Note: *The modules are active when the program is operating and are not closed when minimized. A minimized System Control unit may control a process.*

Workflow

The workflow for using UNICORN system for automatic control includes these general steps:

Step	Action
1	Program an ÄKTA ready method run using the UNICORN software. It is possible to use an existing method or modify an existing method to meet your run objectives.
2	Start the run using the method you created.
3	Monitor the run's progress using the System Control module. All the data about your run is displayed in the System Control module. You have a choice of four different panes that can be open one at a time or all at once, in separate parts of the window.
4	After completing the run, you can display the data in a detailed report using extensive tools provided by the UNICORN Evaluation Module .

Warnings

Warnings are generated to warn operating personnel that process parameters have exceeded preset high and/or low limits, and that the process method continues.

Alarms

Signals

If equipment is connected that has lower limits than the system, the alarm levels must be set accordingly.

If an analog or digital signal passes the predetermined alarm level, several things happen at once:

- The system is set to **Pause** mode.
- The valves and other components on the system are set to their default positions.

The **Valve Pause Function** can be enabled in UNICORN for certain components (air trap, column) to retain the original valve positions.

Test

To test a specific instrument alarm it is possible to lower the alarm limit for the instrument below the current process value.

Reset

The alarm is reset through the control system by acknowledging the alarm message. The process can be started again using the **Continue** function in UNICORN, if the situation has been rectified.

4 Installation

About this chapter

This chapter describes how to transport and install ÄKTA ready.

ÄKTA ready is designed for ease-of-use. As a consequence, the system is easy to install and setup for the first run. Most of the components are mounted on the system cabinet or on the flow kit.

There are few loose parts that require assembling or mounting, and the physical connections are simple and straightforward. Installation should, however, always be performed by experienced personnel authorized by GE Healthcare.

Apart from a suitable environment for the instrument, the prerequisites for installation of ÄKTA ready include outlets for electrical power and compressed air, and access to a computer. Some tools are required for unpacking the instrument, and test liquids must be prepared.

Precautions



WARNING

Before attempting to perform any of the procedures described in this chapter, you must read and understand all contents of the corresponding section(s) in the [Section 2.1 Safety precautions, on page 16](#), as listed below:

- [Installing and moving, on page 18](#)
- [Personal protection, on page 18](#)



NOTICE

ÄKTA ready shall be installed and prepared by GE Healthcare personnel or third party authorized by GE Healthcare.

Contact GE Healthcare if you require re-installation at a new site.

In this chapter

This chapter contains the following sections:

Section	See page
4.1 Included in the delivery	62
4.2 Site requirements	63
4.3 Transport	65
4.4 Unpacking	70
4.5 Positioning the system	71
4.6 Connections	72

4 Installation

4.1 Included in the delivery

4.1 Included in the delivery

General

ÄKTA ready is delivered in a wooden box containing:

- the system cabinet,
 - a column trolley,
 - a smaller box containing an accessory kit and user documentation.
-

The accessory kit

The accessory kit delivered with the system contains:

- Bar code scanner (USB),
- two computer network cables (10 and 3 m), and a RJ45 coupling connector,
- key for the back door of the system cabinet,
- compressed air tubing (5 m),
- customer I/O connector,
- CD disks containing UNICORN and ÄKTA ready strategy software,
- documentation, including UNICORN and ÄKTA ready manuals,
- system log book,
- labels for configured voltage.

A 10 mm wrench for the bolts holding the pump lid is also located on the inside of the front cabinet door.

Associated products

ÄKTA ready gradient pump is optional and used together with the ÄKTA ready gradient flow section.

ÄKTA ready is intended for use with ÄKTA ready flow kits (ÄKTA ready Low Flow Kit or ÄKTA ready High Flow Kit) and ReadyToProcess™ columns up to 20 L.

Flow kits and columns are ordered separately. See [Chapter 14 Reference information, on page 201](#) for ordering information and lists of available flow kits and columns.

4.2 Site requirements

Precautions



WARNING

Explosive environment. ÄKTA ready is **not approved** for work in a potentially explosive atmosphere, in areas classified as Zone 0 to Zone 2 according to IEC 60079-10 2002. ÄKTA ready does not fulfill the requirements of the ATEX Directive.



CAUTION

Do not use ÄKTA ready in a dusty atmosphere or close to spraying water.



CAUTION

ÄKTA ready is designed for indoor use only.

Dimensions of ÄKTA ready

Property	ÄKTA ready	ÄKTA ready gradient
Width / Depth / Height	100 × 80 × 165 cm	116 × 80 × 165 cm
Weight	230 kg	250 kg

Ambient environment

- Relative air humidity 20% to 95%, non-condensing.
- Particle free (filtered) air.
- Clean and dust-free environment.
- Temperature +2°C to +30°C (-25°C to +60°C for storage).
- Atmospheric pressure 950-1050 mbar.

4 Installation

4.2 Site requirements

Compressed air

- Dry and particle free air
 - Airflow 50 NI/min
 - Working pressure 5.5 to 10 bar
 - Air hose connector, a 5 m long air hose with an inner diameter of 7.5 mm is supplied with the system.
-

Electrical power

- Delivered with a permanent power cable, equipped with an IEC 60309 connector.
- Preconfigured for 230V 50/60 Hz AC power supply.

See [Section 4.6 Connections, on page 72](#) for instruction on how to reconfigure the power supply.

4.3 Transport

Crate dimensions

The ÄKTA ready is delivered in a crate. The crate dimensions are different if it is an ÄKTA ready or an ÄKTA ready gradient.

ÄKTA ready

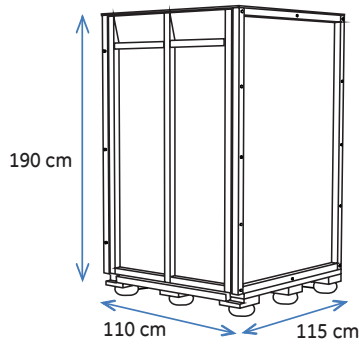

ÄKTA ready gradient

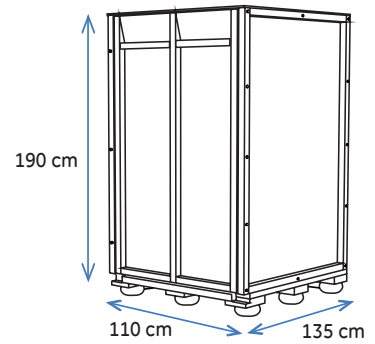

Moving the crate

Use a pallet jack or forklift with a minimum capacity of 400 kg to move and lift ÄKTA ready in the crate. Make sure that intended openings and apertures are large enough to allow passage of the crate when lifted from the floor for transport.

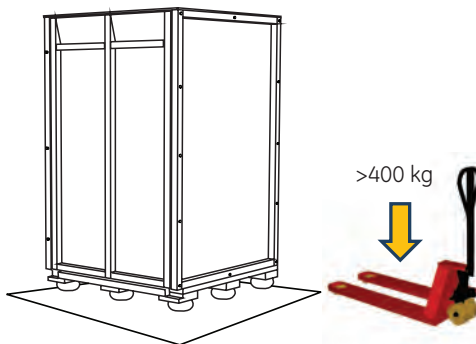

Release wheels to move ÄKTA ready

The ÄKTA ready can be rolled on hard and level surface with brakes on wheels released.

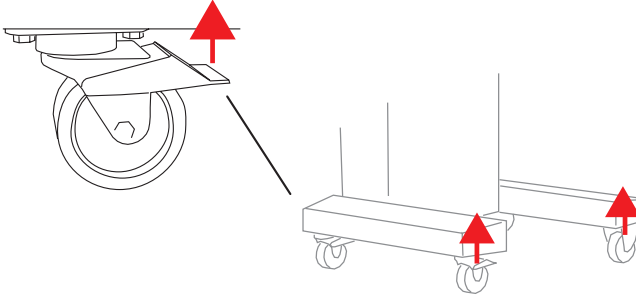

Use the handle to move ÄKTA ready

Use the handle on the left side of the cabinet to maneuver ÄKTA ready.

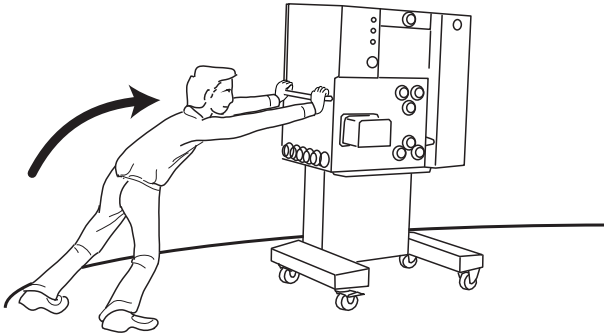

Lifting ÄKTA ready

There are no lifting hooks on ÄKTA ready. Use a forklift or a pallet jack with a minimum capacity of 400 kg for lifting the system. Appropriate safety precautions should be followed.

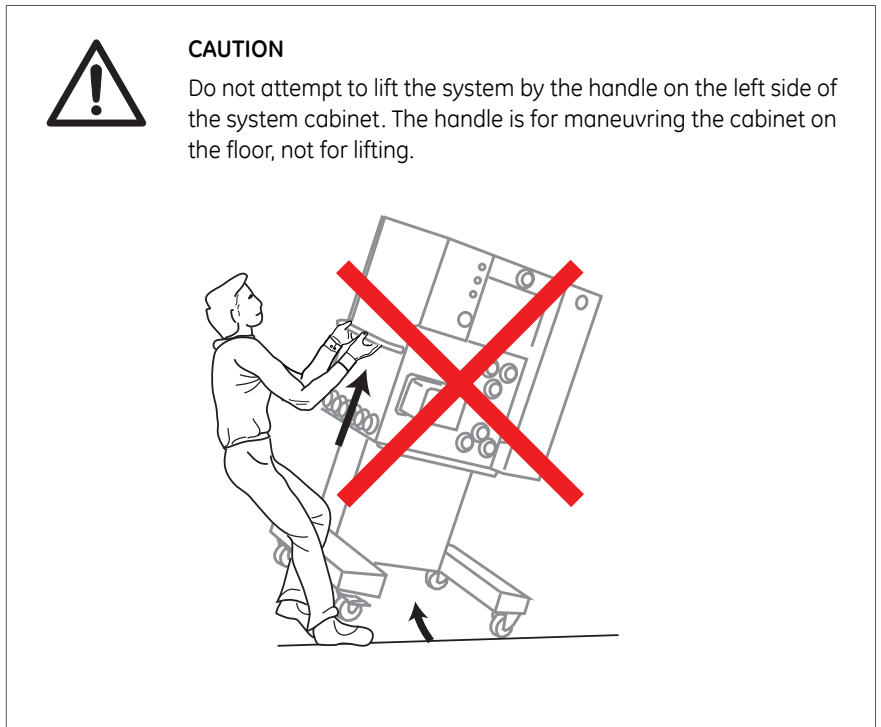

Center of gravity

The center of gravity for ÄKTA ready is indicated with a dashed and dotted, vertical line in the drawings below.

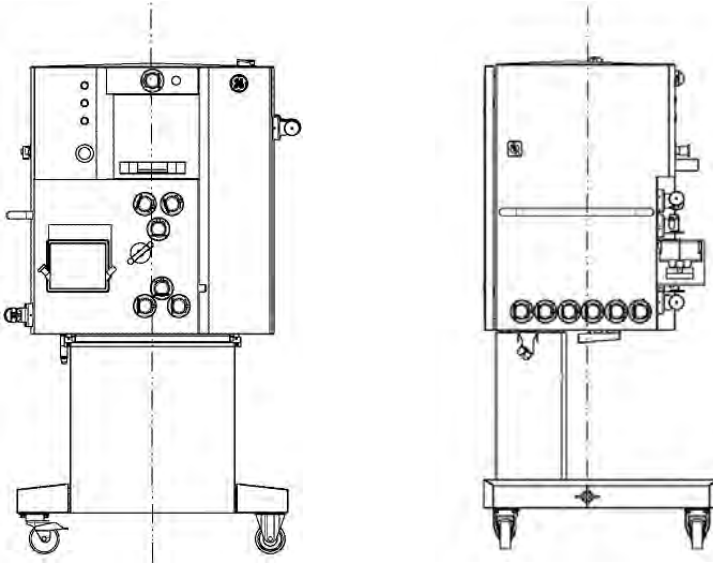

Note: *The line is located slightly towards the back of the cabinet. This must be taken into consideration when moving or lifting the cabinet.*

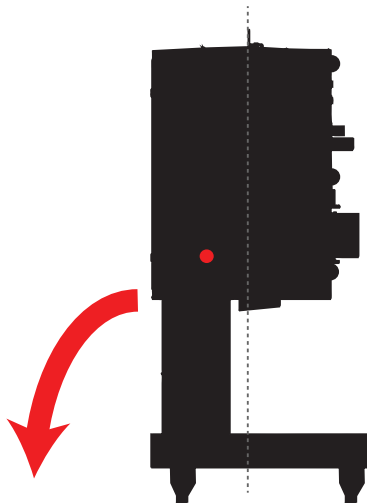

Positioning forks

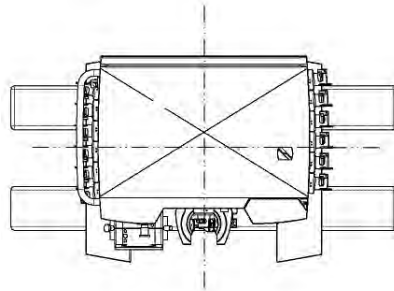

- EU

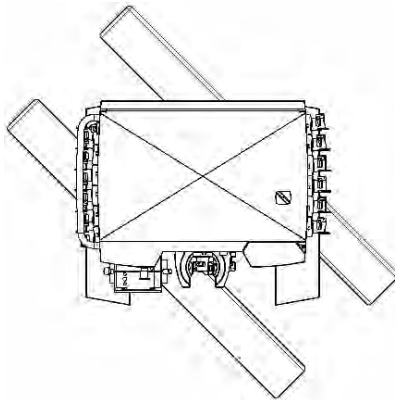

- US

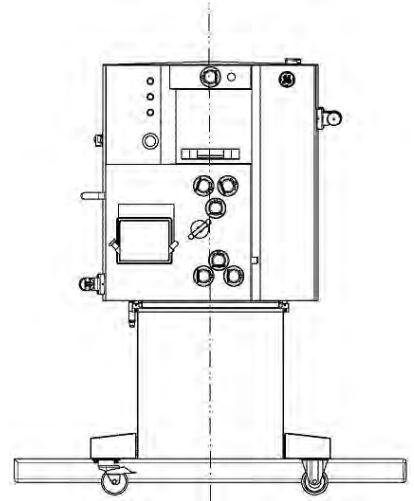

4.4 Unpacking

Check for damage

Check the equipment for damage before starting assembly and installation. There are no loose parts in the crate. All parts are either mounted on the system or located in the accessory kit box. If any damage is found, document the damage, and contact your local GE Healthcare representative.

Safety Precautions



WARNING

Personal Protective Equipment (PPE). Whenever packing, unpacking, transporting or moving ÄKTA ready, wear:

- Protective footwear, preferably with steel lining.
- Working gloves, protecting against sharp edges.
- Protective glasses.



WARNING

Because of the significant weight of ÄKTA ready, great care must be taken not to cause squeezing or crushing injuries during movement. It is recommended that two persons move the system.



WARNING

At least two persons are required to unpack ÄKTA ready gradient!

Instructions for unpacking

For a full description of how to unpack ÄKTA ready refer to the following unpacking instructions:

- *ÄKTA ready Unpacking instructions*, article number 28-9944-89, and
 - *ÄKTA ready gradient Unpacking instructions*, article number 29-0420-82
-

4.5 Positioning the system

Note: The area required at the production location for ÄKTA ready is 280 x 300 cm, allowing for 100 cm of free space on all sides of the system. The ÄKTA ready gradient needs slightly more free space (280 x 316 cm).

The space is required to make room for containers and hoses, and to allow for easy access to the power switch and to connectors on the back of the unit. The back door of the cabinet must furthermore be accessible for service.



WARNING

Access to power switch and power cord. The power switch must always be easy to access. The power cord must always be easy to disconnect.

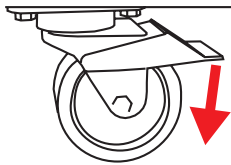

ÄKTA ready arrives pre-assembled in the transport crate. No specific assembly prior to site installation is required. After positioning the system at its designated location, lock the wheels (figure).



NOTICE

Check that the Pressure Control Regulator for the system air supply is set to the pressure stated in the specifications.

4.6 Connections

Connector locations

A cable for system power is permanently mounted on the back of the system cabinet. Connectors for pressurized air, computer network and customer I/O are also located on the back of the system unit, at the bottom of the cabinet. Two computer network cables, and a connector for the customer I/O are supplied but not mounted. For more information about connector locations, see [Components on system cabinet — back, on page 46](#).

Power



WARNING

High voltage. The mains cable must only be connected by authorized service personnel. Faulty connection might result in live system parts that can give lethal electric shocks.



WARNING

Do not turn on the **Mains power** switch before all connections are made.

Power connection

The mains power supply must be connected and configured by authorized service personnel. Please contact your GE Healthcare representative.

Compressed air



NOTICE

Check that the Pressure Control Regulator for the system air supply is set to the pressure stated in the specifications.



CAUTION

Make sure that correct air pressure is always maintained. Too high or too low air pressure may be hazardous and may cause erroneous results and leakage.

Instruction

Step Action

- 1 Connect your compressed air supply to the air input connector on the back of the system, labeled **PNEUMATIC AIR SUPPLY**. Use the supplied 5 m air hose with inner diameter 7.5 mm.
 - 2 Switch on the air supply.
 - 3 Check for air leaks.
-

Computer

Requirements



WARNING

Installing the computer. The computer should be installed and used according to the instructions provided by the manufacturer of the computer.

UNICORN is the controlling software for ÄKTA ready. It is recommended that the computer used is dedicated to UNICORN and related software. Due to the risk for computer viruses, it is also recommended that the computer is not directly connected to Internet.

See the UNICORN manuals for further details about software requirements and installation.

Instruction

Two network cables are delivered with the system and should be connected according to the instruction below:

Step	Action
1	Connect the encapsulated end of the longer (10 m) straight cable to the connector (of type RJ45) marked SYSTEM COMPUTER on the back of the system.
2	Connect the other end of the long cable to: <ul style="list-style-type: none">• the controlling computer if a direct connection is used, or• the shorter (3 m) crossover cable, which, in turn, is connected to a switch or hub (the shorter cable is only used when connecting to the controlling computer via a network).

Note: *In order not to compromise the protection of the cabinet, use only the enclosed communication cables.*

Customer I/O

Connector

The **CUSTOMER I/O** connector (**C1** in figure below) is located on the left side of the system cabinet, beneath the inlet valves. The connector is a 15-pole IP67-proof Dsub male connector. A female mating connector containing a screw terminal block with water tight housing is supplied with the system.

The **CUSTOMER I/O** connector can be used for an external alarm, and to receive a signal indicating that a UPS has been activated. This is described below.

The **CUSTOMER I/O** connector is also used for connecting the air sensors, as described below.

Connection for alarm or UPS

Input voltage is 24 V (acceptable range 15 to 28 V), and output signal is 24 V/max 1 A.

The signals are:

- Pin **1**: Remote Alarm (**A** in figure) digital output +24 V
- Pin **4**: GND, Digital ground
- Pin **11**: UPS On (**B** in figure), digital input (+24 V)
- Pin **15**: +24 V Digital Supply voltage.

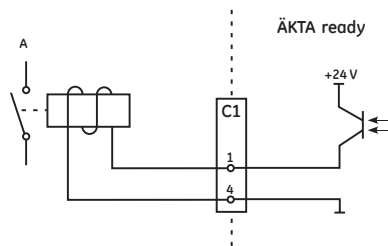

Pins **1** and **4** provide an output for an alarm device (e.g., a warning light, a buzzer, or similar device). The external alarm will be triggered when the internal buzzer is activated.

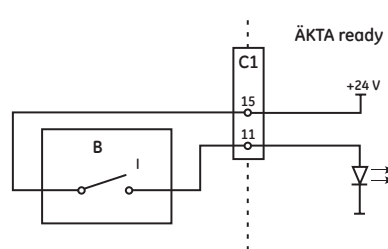

Pins **11** and **15** are used to receive an On signal (**B** in figure) from an (optional) UPS during a power failure.

Connection for air sensors

The air sensors are connected to the **CUSTOMER I/O** as shown in the illustration below.

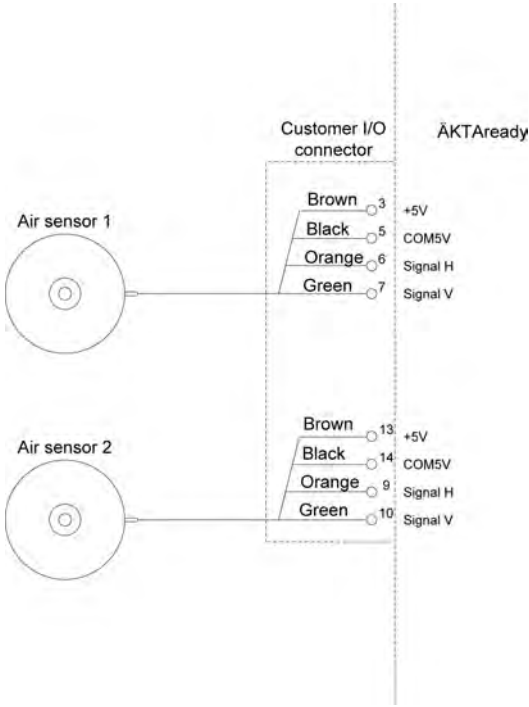

Finishing installation

Verifying connections

Finish installation of ÄKTA ready by verifying that the system is properly connected to mains power, to compressed air supply, and to the computer. Next, verify that communication between UNICORN and the system unit can be established, see instruction below.

Establishing computer connection

Step	Action
------	--------

- | | |
|---|--|
| 1 | <p>Turn on ÄKTA ready using the Mains power switch, located on the left side of the cabinet.</p> <p>Check that the green POWER lamp on the front of the unit lights up (bottom lamp in figure). The light flashes slowly when communication with UNICORN is not established.</p> |
|---|--|



- | | |
|---|---|
| 2 | <p>Switch on the computer and computer screen, and check that a booting process starts.</p> |
|---|---|



- | | |
|---|---|
| 3 | <p>After booting is finished, check that the UNICORN software is installed and available (UNICORN symbol visible on the computer's desktop).
Start UNICORN by double-clicking its icon.</p> |
| 4 | <p>Check that the green POWER lamp now shows a steady green light, indicating that UNICORN recognizes and can communicate with the system unit.</p> |

Installing the barcode reader

The barcode reader is installed and configured as described below.

Note: *Installation requires barcodes to be scanned from the Quick Start Guide supplied with the barcode reader. If the Quick Start Guide is lost, it can be downloaded from the barcode reader manufacturer's web site.*

Step	Action
1	Connect the barcode reader to the computer with a USB cable, as shown in the <i>Quick Start Guide</i> .
2	Locate the USB Keyboard (PC) interface barcode in the <i>Quick Start Guide</i> and scan it using the barcode reader.
3	Place the barcode reader in its holder. The installation is complete when it beeps.
4	To verify the barcode function, open an empty Notepad document (Start:All Programs:Accessories:Notepad). Scan any barcode. A text string should appear in the Notepad document. The Notepad document may be discarded.
5	If the barcode reader does not function, locate the Standard Products Default barcode in the <i>Quick Start Guide</i> and scan it with the barcode reader. Repeat the installation procedure.

5 Starting ÄKTA ready

About this chapter

This chapter describes how to start and log on to UNICORN and ÄKTA ready.

Precautions



WARNING

Before attempting to perform any of the procedures described in this chapter, you must read and understand all contents of the corresponding section(s) in the [Section 2.1 Safety precautions, on page 16](#), as listed below:

- [General precautions, on page 16](#)
-

In this chapter

This chapter contains the following sections:

Section	See page
5.1 Start and log on to UNICORN	80
5.2 Start the system	81

5.1 Start and log on to UNICORN

UNICORN software

The UNICORN control software is delivered with the system. UNICORN should be installed on a PC (optional) with Microsoft Windows operating system (see [Section 3.5 UNICORN control system, on page 57](#) and UNICORN documentation for details). Refer to the UNICORN manuals for installation instructions concerning software.

Starting UNICORN

Refer to [Section 3.5 UNICORN control system, on page 57](#) for more information regarding the UNICORN control system, warnings and alarms.

Step	Action
1	Switch on the computer.
2	Log on to Windows.
3	Start UNICORN by double-clicking on the UNICORN icon on the Windows desktop.
4	When the Logon dialog appears, select a user from the Users list and enter the password. If you log on for the very first time, select default and enter the password default .
5	Click OK .
6	In the System Control module, select System:Connect .
7	In the dialog shown, select the appropriate system name and click OK . The system name is specified during installation configuration.
8	When UNICORN is connected to the system, the Run button in the status bar is enabled. The button initially has a green color indicating the system is ready to run.



5.2 Start the system

General

ÄKTA ready is normally left switched on between runs. The unit is switched off only during monthly maintenance and repair, or when not in operation for a longer period of time (more than a few days).

Starting ÄKTA ready

Step	Action
1	Switch on power to ÄKTA ready by turning the Mains Power switch to the "I" position. See Components on system cabinet – front, on page 43 for location.
2	Make sure that UNICORN is started according to the instruction above. Wait for connection.

After this sequence is completed, the following occurs:

- The **POWER** indicator lamp flashes. See [Components on system cabinet – front, on page 43](#) for location.
- When communication with UNICORN software is established, the **POWER** indicator lamp shows a steady green light.

Note: *When power is switched on ÄKTA ready will perform a stray light calibration without the UV flow cell installed. This will result in a very high calibration factor. Therefore it is very important to perform a stray light calibration as soon as the flow kit is mounted and water or any other actual liquid has been purged through the flow kit.*

6 Flow kit installation

About this chapter

This chapter presents the different flow kits that can be used with the ÄKTA ready, and describes how to install an ÄKTA ready flow kit. Much of the information in this chapter is also available in the ÄKTA ready installation wizard (part of supplied software). How to install the gradient flow section is described in [Section 7.2 ÄKTA ready gradient flow section, on page 103](#).

Precautions



WARNING

Before attempting to perform any of the procedures described in this chapter, you must read and understand all contents of the corresponding section(s) in the [Section 2.1 Safety precautions, on page 16](#), as listed below:

- [General precautions, on page 16](#)
 - [Flammable liquids and explosive environment, on page 17](#)
 - [Personal protection, on page 18](#)
 - [Operation, on page 21](#)
-

In this chapter

This chapter contains the following sections:

Section	See page
6.1 ÄKTA ready flow kits	83
6.2 Unpacking the flow kit	85
6.3 Mounting the flow kit	86

6.1 ÄKTA ready flow kits

Three parts

ÄKTA ready flow kits are delivered in three parts. Each of the three parts constituting the flow path are sanitized and ready for use with the ÄKTA ready.

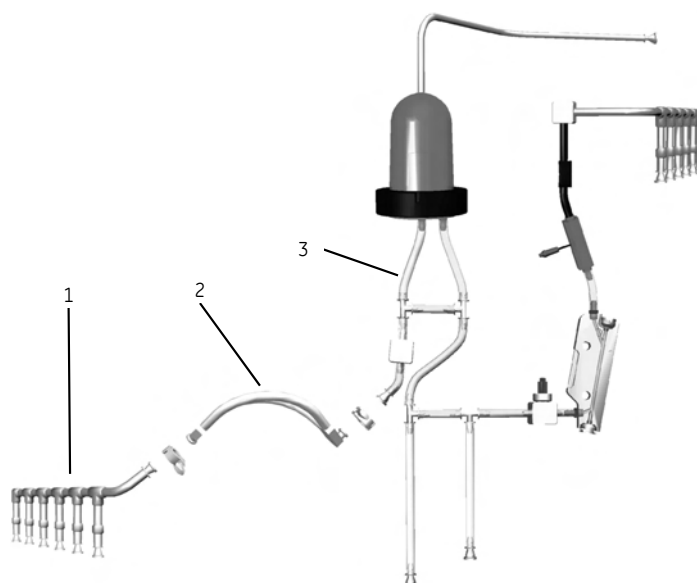

No.	Part	Function
1	Inlet manifold	Tubing with 6 connectors for inlets and one for the pump tubing.
2	Pump tubing	Double pump tubing for mounting in the peristaltic pump, with connectors to inlet tubing and to the main part of the flow kit tubing.
3	Main part	Tubing with all required flow cells (pressure, flow meter, temperature, conductivity, and UV), air trap, 6 outlets, and connectors to pump tubing and column. Note: <i>The pH electrode is optional. For ordering information, see Section 14.4 Ordering information, on page 211.</i>

6 Flow kit installation

6.1 ÄKTA ready flow kits

It is possible to assemble a flow kit before it is mounted onto the system cabinet. The recommended procedure, however, is to connect the three parts to each other in connection with mounting of the flow kit. This is the procedure described in this chapter.

Flow kit types

Two different ÄKTA ready flow kits are available:

- ÄKTA ready High Flow Kit, with tubing diameter 9.5 mm (inlet manifold 12.7 mm, pump tubing 12 mm). Intended for 10-20 liter ReadyToProcess columns.
- ÄKTA ready Low Flow Kit, with tubing diameter 6.4 mm (inlet manifold 9.5 mm, pump tubing 8 mm). Intended for columns with a volume of less than 10 liters.

Both flow kits use 25 mm TC connectors for connecting to inlet and outlet containers, pump tubing, and column.



NOTICE

Only use ÄKTA ready flow kits, supplied by GE Healthcare.

Specifications for ÄKTA ready flow kits are found in [ÄKTA ready flow kit specifications, on page 203](#). Ordering information is in [ÄKTA ready flow kits, on page 211](#).

6.2 Unpacking the flow kit

Flow kit package

To protect against contamination, ÄKTA ready flow kits are delivered in double plastic bags.

The flow kit package contains the following items:

- The main part of the flow kit and the inlet manifold (6 inlets). The main part includes air trap, column connection tubing, sensor flow cells, and outlet manifold (6 outlets).
 - The pump tubing, including 2 TC clamps with gaskets.
 - Vaseline.
 - A binder containing product documentation for the flow kit.
-

Unpack flow kit

Unpack ÄKTA ready flow kits as follows:

Step	Action
1	Cut open the outer plastic bag in a clean environment near the ÄKTA ready, for example in the air lock, if the system is in a clean room.
2	Take out the inside plastic bags and move them together with the other flow kit equipment to the system cabinet. Open the bags immediately before mounting the flow kit onto the system cabinet.

Note: *In addition to the plastic wrappings, ÄKTA ready flow kits are equipped with plastic end caps protecting the connectors from contamination. Do not remove any of the end caps until it is time to connect the flow kit to buffer bags/tanks and to column, which are the last steps in the mounting procedure (see [Section 6.3 Mounting the flow kit, on page 86](#) and [Section 9.2 Installing a column, on page 130](#)).*

Labeling of flow kits

The different parts of the ÄKTA ready flow kits are labeled and equipped with bar codes. The bar codes are primarily used for traceability. ReadyToProcess Columns have bar codes for the same purpose.

6.3 Mounting the flow kit

Introduction

This section contains a step-by-step description of how to install a flow kit onto the ÄKTA ready cabinet. The procedure described here is an extended version of the procedure described in the **Flow Kit Installation** part of the **ÄKTA ready Installation Wizard**. There is, however, no direct correspondence between the numbering of the steps in the wizard and the numbering used here.

You are recommended to always use the wizard when installing a new flow kit. It helps to ensure that all the steps are performed, and performed in the right order. The wizard thereby provides a simple way of securing the correctness of a flow kit installation. The wizard also includes a component test and provides the option of producing a printed report containing installation information and test results.

Before starting

System setup

In the component list under **Administration: System Setup** in the UNICORN Manager, select **Profibus_Config5** or **Profibus_Config6**. If you have installed the gradient system both **Äkta_Ready_Gradient** and **Profibus_Config6** must be selected.

You should also select **pH_Cell** if pH is to be measured, the correct flow kit size (**LowFlow_Kit**, default, or **HighFlow_Kit**), type of air sensor (**Air_AE151** or **Air_AE152**). **Service** provides the possibility to display **UV_131_S** and **UV_131_R** in **RunData**.

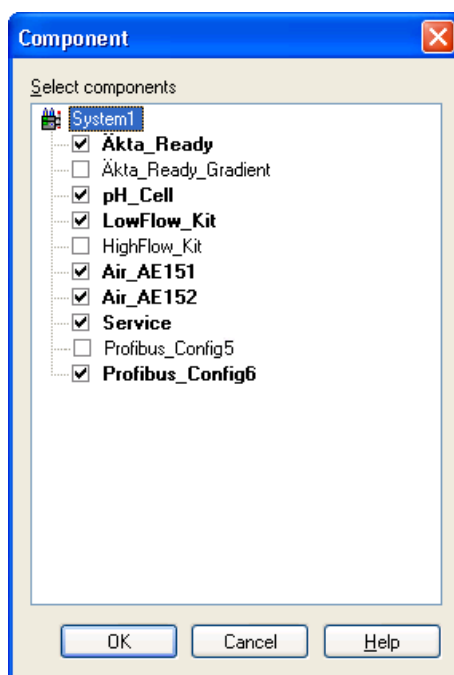

TC clamps

Two TC clamps are provided with the flow kit. An additional three clamps are required in order to mount the flow kit and run a component test.

Aseptic solution

A suitable disinfectant solution should be available for aseptic treatment of tubing connectors. Connectors can, for instance, be treated with 70% Ethanol before connecting.

End caps

At delivery, all connectors on the flow kit, except those on the pump tubing, are covered by protective end caps. The caps are removed during installation. Remember to save the end caps as they are used to seal the tubing when the flow kit is removed and disposed of (see [Section 11.4 After the run, on page 181](#)).

6 Flow kit installation

6.3 Mounting the flow kit

Test liquids

Wash and test liquids required for component testing should be prepared after mounting a new flow kit. It is important that the liquids, which contain acetone are freshly prepared. For details about volumes and concentrations required see description in [Prepare a test, on page 113](#). A **Test solution preparation protocol** template is available on the ÄKTA ready CD.

pH calibration

If pH is to be measured, the pH electrode should be calibrated and sanitized before installing the flow kit. pH calibration is described in [pH calibration, on page 187](#).

Open the installation wizard

Step	Action
1	To start the installation wizard, select File:Instant Run... in ÄKTA ready Control module and press Run in the dialog shown.
2	In the wizard, select Flow kit Installation with Component Test . Installation of a new flow kit normally includes a component test.
3	Select Print Report Automatically if you want to automatically print a report with installation information and test results. A printed report can also be produced later, by selecting AKTA ready_FlowKit under File:Report in ÄKTA ready System Control module.

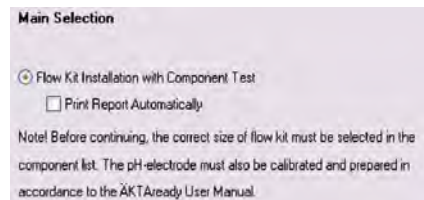

Open all safety locks on pinch valves

The safety locks keep the pinch valves locked in an open position, thereby preventing injuries due to, for instance, a faulty compressed air supply. To open them:

Step	Action
------	--------

- | | |
|---|--|
| 1 | Start the installation by turning the Installation switch (in the upper, right corner of the system cabinet) to its left position, FLOW KIT INSTALL . UNICORN must be in END mode. |
|---|--|

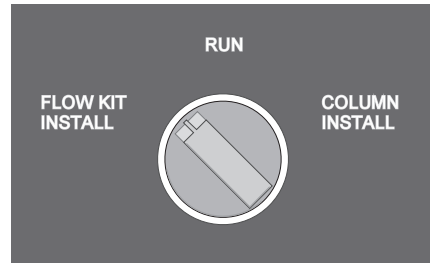

- | | |
|---|--|
| 2 | Open the safety locks on all pinch valves. The valve safety locks are opened by turning the black handles 180 degrees. There are 19 valves in total. |
|---|--|

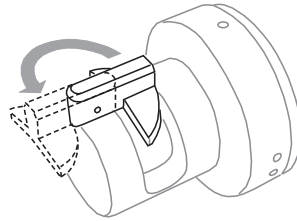

Remove the pump lid

Step	Action
------	--------

- | | |
|---|---|
| 1 | Locate the bolts holding the pump lid. Use the supplied 10 mm wrench, located on the inside of the front cabinet door, to rotate the right-hand bolt counter-clockwise, and the left-hand bolt clockwise, until both are fully open. It will be necessary to reposition the wrench. |
|---|---|

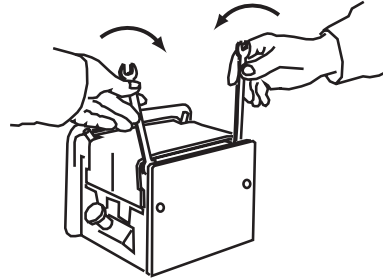

- | | |
|---|--|
| 2 | Check the position of the two pegs at the back of the lid. The pegs indicate when the bolts are fully open/closed. |
|---|--|

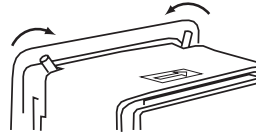

- | | |
|---|---|
| 3 | Lift the pump lid and remove it completely. |
|---|---|

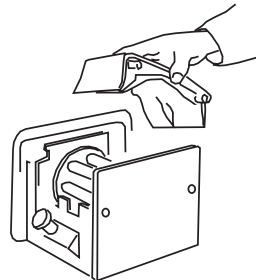

Open pressure cell holders

- | Step | Action |
|------|---|
| 1 | Locate the three pressure cell holders for pressure sensors PT-111 , PT-112 , and PT-113 . |



- | | |
|---|---|
| 2 | Release (but do not remove) the screws on the latches, and turn the latches open. |
|---|---|

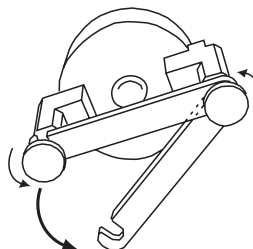

Mount the inlet manifold

Step	Action
1	Open the plastic package containing the inlet manifold and main part of the flow kit.
2	Retrieve the inlet manifold and mount it on the system cabinet by inserting each inlet tubing into the corresponding inlet pinch valve (XV-001 to XV-006). Do not yet remove the end caps.
3	Close each safety lock on the pinch valves by turning the black handles 180 degrees.



Attach the main part tubing

Step	Action
1	Lift the main part of the flow kit (see image) using: <ul style="list-style-type: none">• your left hand to hold the tubing by the air trap• your right hand to hold the UV cell. Avoid touching the window.
2	Place the air trap in its holder, and insert the UV cell in the slot to the right of the air trap. Push the UV cell all the way in. A soft click indicates that it is properly positioned.
3	Place the outlet manifold in the gap between of the cabinet and the front cabinet door for the time being. (Do not mount it yet.)

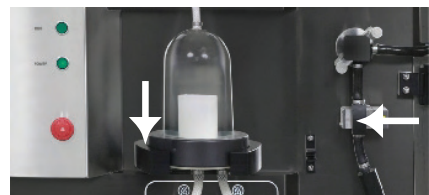
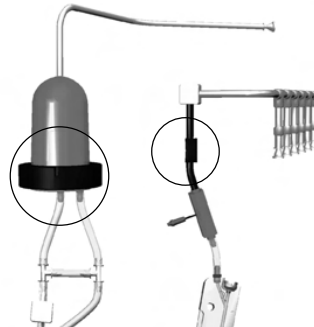

Connect and mount the pump tubing

Step	Action
------	--------

- | | |
|---|--|
| 1 | Open the plastic bag containing the pump tubing and place the tubing on top of the pump rollers with the larger connector block (the block with the connector for the main part of the flow kit) to the right. |
|---|--|

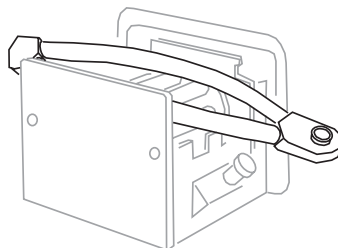

- | | |
|---|---|
| 2 | Push the pump tubing over the mounting knob on the right hand side of the pump. |
|---|---|

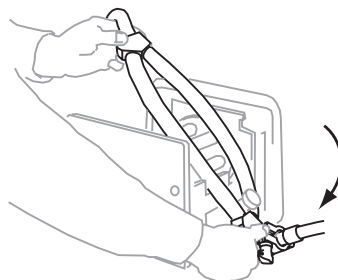

- | | |
|---|---|
| 3 | Stretch the tubing, and push it over the left hand mounting knob. |
|---|---|

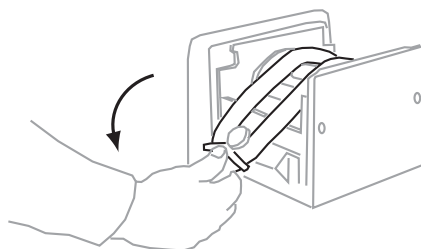

- | | |
|---|--|
| 4 | Using TC clamps, connect the right hand connector of the pump tubing to the main part of the flow kit, and the left hand connector and the sealings to the inlet manifold. |
|---|--|

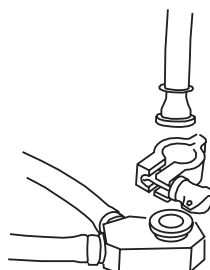

6 Flow kit installation

6.3 Mounting the flow kit

Step	Action
------	--------

5	To attach the pump lid:
---	-------------------------

- Press down the pump lid with one hand,
- Secure it by rotating the left and right bolts counter-clockwise and clockwise, using the supplied wrench (also see [Remove the pump lid, on page 90](#)).
- The pegs at the back of the lid indicate when the bolts have been turned all the way. The pegs should be in their lowermost position when the lid is closed. Note that the system will not work if the lid is not properly secured.

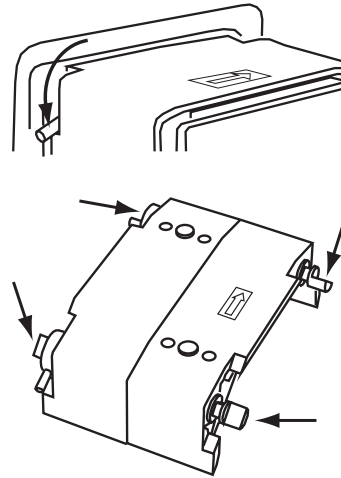

Note:

Do not turn the pump lid the wrong way around! The arrow label on the lid indicates the flow direction and should point to the right. The pegs should be located at the back of the lid, on the side closest to the instrument.

Mount the main part tubing

- | Step | Action |
|------|---|
| 1 A | <p>Pinch valves:</p> <p>Insert the tubing into the air trap valves (1-3 in figure), the column valves (4-6), and the air release valve (7). Proceed in the order indicated by the numbers in the figure (i.e., start with the air trap valves).</p> |
| 1 B | <p>Close the valve safety locks as you proceed.</p> |

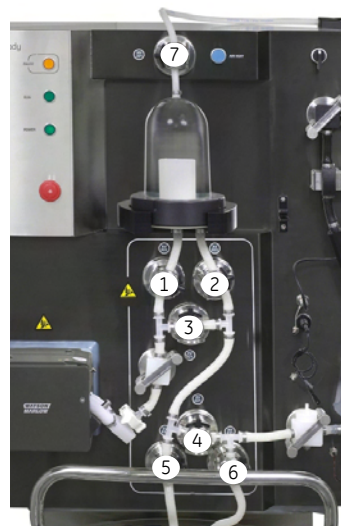

Note:

Make sure the pH cable does not get trapped behind the tubing. The cable should be attached to its holder on the cabinet.

- | | |
|-----|---|
| 2 A | <p>Pressure cells:</p> <p>Attach the three pressure cells (for sensors PT-111, PT-112, and PT-113) by pushing them onto their respective pressure cell adapters on the cabinet.</p> |
| 2 B | <p>Secure the cells by turning the latch over the pressure cell body, and fasten the screws.</p> |
| 2 C | <p>Before firmly fastening the screws, check that the cell is correctly positioned and that there is no gap between the cell body and the adapter. Apply finger force only.</p> |

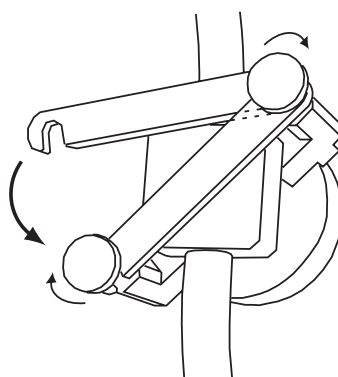

6 Flow kit installation

6.3 Mounting the flow kit

Step	Action
------	--------

3 A	Flow meter cell:
-----	-------------------------

Align the holes in the body of the flow meter cell (**FE-141**) with the two knobs on the cabinet (see **1** and **2** in figure) and push the cell into place.

3 B	Clean the contact surfaces of the transducer connectors (bayonet couplings) and apply a layer of Vaseline.
-----	--

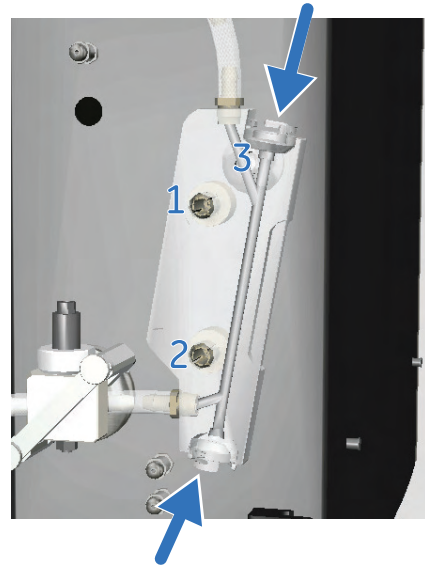

Note:

Make sure that enough Vaseline is applied to the transducer connectors. (Any surplus Vaseline will be squeezed out and can be removed with a tissue.)

3 C	Connect the transducers to the connectors at the top and bottom of the flow cell (see arrows in figure).
-----	--

On the back of the flow meter cell is a window for the temperature sensor (**3** in figure). The window is automatically aligned with the temperature sensor when the flow meter cell is mounted. No further action is necessary to prepare for temperature measurements.

Note:

Make sure the flow meter cell is properly pushed onto its mounting knobs. A soft click indicates correct mounting. Improper mounting of the flow meter cell may result in erroneous temperature measurements and leakage.

Step	Action
------	--------

4 A	Conductivity cell: Unscrew the protective cap (1) on the system cabinet's conductivity connector.
-----	---

4 B	Connect the conductivity sensor by screwing its cable connector (2) onto the connector on the system cabinet.
-----	---

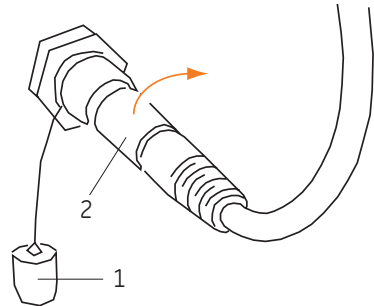

Note:

Before inserting the connector, make sure it is correctly positioned. There is a small ridge on the male connector and a corresponding groove on the female connector. Do not use force when inserting the connector.

6 Flow kit installation

6.3 Mounting the flow kit

Step	Action
------	--------

5 A	pH electrode:
-----	----------------------

Unscrew the plastic fastening nut (1) on top of pressure cell (PT-112) and pull out the dummy from the electrode holder (2).

5 B	Release the pH cable from its storage position by unscrewing the lower cable connector from the system cabinet. <i>Do not unscrew the upper connector!</i>
-----	--

5 C	Calibrate and sanitize the pH electrode. See pH calibration, on page 187 for calibration instructions.
-----	--

5 D	Make sure the O-ring (3) is in place in PT-112.
-----	---

5 E	Push the pH cable through the fastening nut, and connect the pH electrode (AE-121) to the cable.
-----	--

5 F	Insert the pH electrode in its holder. Secure the electrode with the plastic fastening nut. Use finger force only.
-----	--

6	UV cell:
---	-----------------

The UV cell is mounted when the main part of the tubing is attached to the system cabinet. No further actions are required to connect the UV sensor. However, make sure that the cell has been pushed all the way in (a soft click indicates that the cell is in correct position).

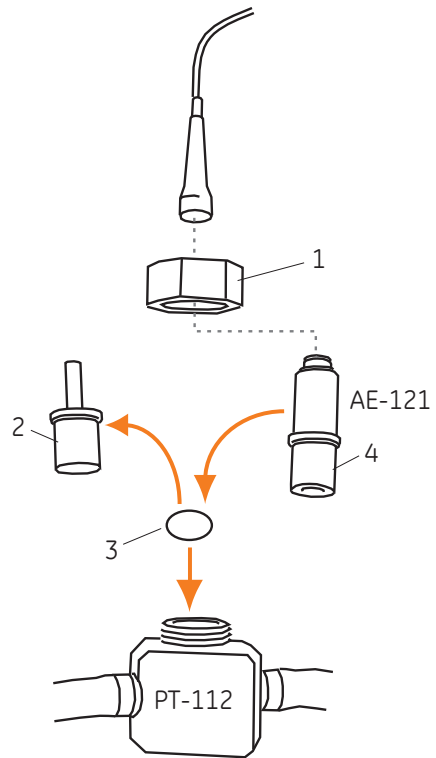

Mount the outlet tubing

- | Step | Action |
|------|---|
| 1 | Mount the outlet manifold by inserting each outlet tube into the corresponding outlet pinch valve (valves XV-051 to XV-056). Do not yet remove the end caps. |
| 2 | Close each valve safety lock by turning the black handles 180 degrees. |
| 3 | Snap the air vent tubing (that runs from the top of the air trap) onto the holder (1 in figure) on top of the system cabinet, and remove the protective end cap (2) from the end of the air vent tubing. |

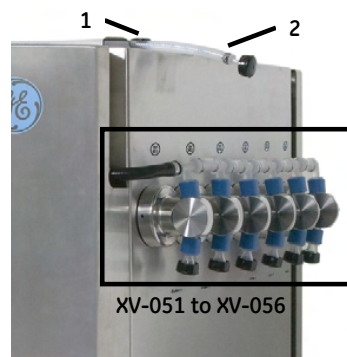

Note:

Remember to remove the protective end cap from the air vent tubing. The air trap will not work properly if the cap is left in place.

Finishing flow kit installation

- Make sure that the safety locks on all pinch valves have been properly closed. There are 19 safety locks in total.
- Make sure that the three pressure flow cells are in place and properly connected.
- Set all pinch valves to run position by turning the **Installation switch** to **RUN**.
- Check that the end cap on the air vent tubing of the air trap has been removed.

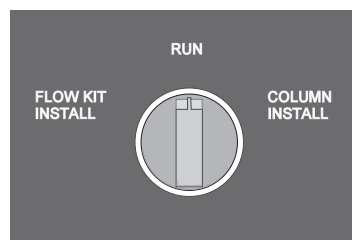
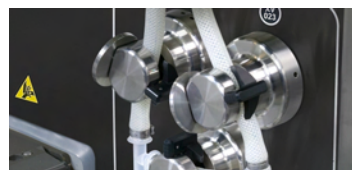

6 Flow kit installation

6.3 Mounting the flow kit



NOTICE

The end of the air trap tubing should be directed away from the operator (preferably, it should be connected to a waste hose).

A component test should always be performed after mounting a new flow kit. If the installation wizard is used, a component test is automatically included in the installation procedure. The component test is described in [Chapter 8 Component test, on page 111](#).

Alternative mounting procedure

To minimize microbiological contamination it is possible to assemble a flow kit in, for instance, a LAF cabinet before it is mounted onto the system cabinet. However, if you decide to pre-assemble a flow kit, be careful to check that the angles between the different parts are correct. If they are not, the flow kit will not fit properly on the cabinet, possibly causing kinked tubing. To adjust the different parts it is necessary to loosen the TC connectors.

Connecting the flow kit parts after they have been mounted on the cabinet is the recommended procedure since this ensures correct positioning. Stray light calibration should be done prior to run of system.

7 ÄKTA ready gradient

About this chapter

This chapter provides an overview of the details of ÄKTA ready gradient. It describes how to install the ÄKTA ready gradient flow section. It also provides an instruction how to calibrate the pump.

Gradient linearity is $\pm 4\%$ between 10% to 90%.

Precautions



WARNING

Before attempting to perform any of the procedures described in this chapter, you must read and understand all contents of the corresponding section(s) in the [Section 2.1 Safety precautions, on page 16](#), as listed below:

- [General precautions, on page 16](#)
- [Flammable liquids and explosive environment, on page 17](#)
- [Personal protection, on page 18](#)
- [Operation, on page 21](#)

In this chapter

This chapter contains the following sections:

Section	See page
7.1 ÄKTA ready gradient pump	102
7.2 ÄKTA ready gradient flow section	103
7.3 Calibrate and operate the ÄKTA ready gradient pump	107

7.1 ÄKTA ready gradient pump

Introduction

ÄKTA ready gradient pump consists of a stainless steel box containing a pump motor, a pump head and electrical cables. It also includes a motor driver installed inside the ÄKTA ready cabinet.

The gradient pump is mounted on the left foot of ÄKTA ready.

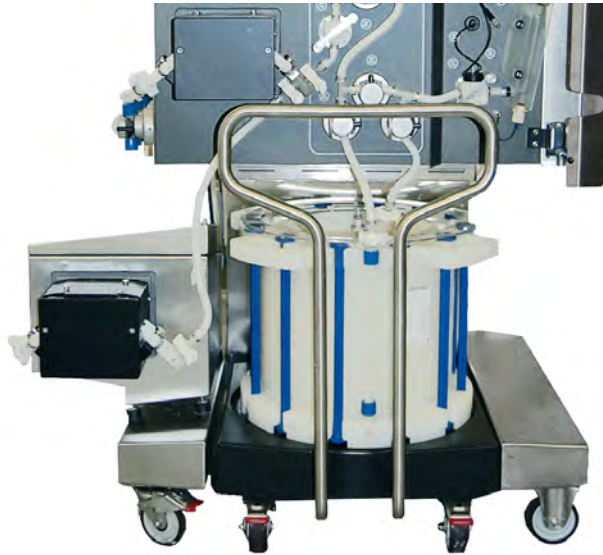

7.2 ÄKTA ready gradient flow section

Two parts

ÄKTA ready gradient flow section are delivered as two parts. Each of the two parts constituting the flow parts are autoclaved and ready for use with ÄKTA ready.



No.	Part	Function
1	Pump tubing	Double pump tubing for mounting to system pump (P-201).
2	Jumper tubing	Tubing to be connected to ÄKTA ready gradient pump (P-202).

Gradient flow section types

Two different ÄKTA ready gradient flow sections are available:

- ÄKTA ready gradient High Flow section, with pump tubing diameter 12 mm and tubing diameter 9.5 mm.
- ÄKTA ready gradient Low Flow section, with with pump tubing diameter 8 mm and tubing diameter 6.4 mm.

Both flow kits use 25 mm TC connectors for connecting to inlet and outlet containers, pump tubing, and column.



NOTICE

Only use ÄKTA ready flow sections, supplied by GE Healthcare.

Specifications for ÄKTA ready flow kits are found in [ÄKTA ready gradient section specifications, on page 204](#). Ordering information is in [ÄKTA ready gradient flow section, on page 211](#).

Installation of gradient flow section

If you have selected the ÄKTA ready gradient options in the **Component List** on page [87](#), you can follow the **ProductNameSW** wizard to install the ÄKTA ready gradient flow section. You may also follow the instruction below.

More information about mounting the flow kits can be found in [Section 6.3 Mounting the flow kit, on page 86](#).

Step	Action
------	--------

- | | |
|---|--|
| 1 | Take the ÄKTA ready pump tubing from the ÄKTA ready flow kit package. For a description of the content of the ÄKTA ready flow kit package refer to Three parts, on page 83 . |
|---|--|



Step **Action**

- 2 Place the ÄKTA ready pump tubing on the ÄKTA ready gradient pump (**P-202**).

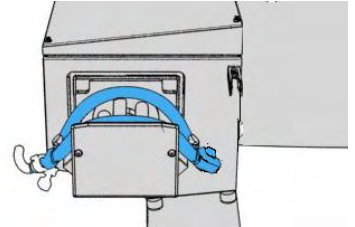

- 3 Take the ÄKTA ready gradient pump tubing from the ÄKTA ready gradient flow section package. For a description of the content of the ÄKTA ready gradient flow section package see [Two parts, on page 103](#).

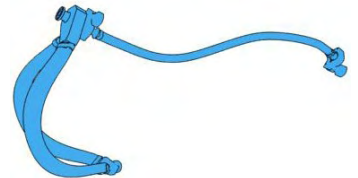

- 4 Place the ÄKTA ready gradient pump tubing from the ÄKTA ready gradient flow section package on the the ÄKTA ready system pump (**P-201**).

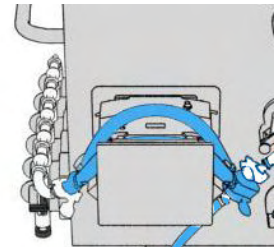

- 5 Take the jumper tubing from the ÄKTA ready gradient flow section package.

- 6 Connect the jumper tubing to the right side of the ÄKTA ready pump tubing (placed on the gradient pump) using a TC clamp.



7 ÄKTA ready gradient

7.2 ÄKTA ready gradient flow section

Step	Action
------	--------

- | | |
|---|--|
| 7 | Connect the other end of the jumper tubing to the right side of the ÄKTA ready gradient pump tubing (placed on the the system pump). |
|---|--|

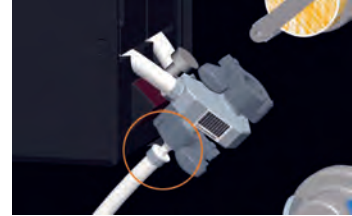

- | | |
|---|---|
| 8 | Connect the inlet manifold to the left side of the ÄKTA ready gradient pump tubing placed on the ÄKTA ready system pump (P-201) using a TC clamp. |
| 9 | Connect the B-buffer tubing to the left side of the ÄKTA ready system pump tubing placed on the ÄKTA ready gradient pump (P-202) inlet 7 using a TC clamp. |

7.3 Calibrate and operate the ÄKTA ready gradient pump

Introduction

The calibration procedure compensates for differences in capacity of pump A (**P-201**) and pump B (**P-202**) at a given motor speed, as a result of pump tubing position and properties. With the assumption that each pump has a linear behavior of flow rate vs. rpm within a given range of operating pressure, a compensation factor is determined within the calibration procedure to allow a synchronization of the pumps against a nominal volumetric gradient.

Pump compensation

Step	Action
1	Start the system pump at a flow rate planned for the actual separation.
2	When flow rate is stable press P201Gain and shift to Gradient 100%.
3	When flow rate is stable press P202Gain and shift to Gradient 0% and activate Flow_Compensation .

Calibration procedure

Pump A (**P-201**) is ramped up to a target flow rate and the rpm value is recorded (by execution of the instruction **P201Gain**). In a second step, pump B (**P-202**) is ramped up to the same target flow rate and the actual rpm value is recorded (by execution of the instruction **P202Gain**). Then a compensation factor (**P202Factor**) is calculated for Pump B to achieve identical flow rate vs. rpm characteristic as Pump A.

The compensation factor is generated in UNICORN by switching **FlowCompensation** to **ON**. The actual **FlowCompensation** value can be displayed in **RunData**.

Note: *Pump tubing is more sensitive to wear and tear. If worn tubing is used the gradient system must be calibrated more frequently.*

Set up for calibration

The set up for calibration procedure is run to ensure that no air bubbles are present in the system tubings. A column should be connected to make the calibration conditions similar to those of a real run.

Step	Action
------	--------

- | | |
|---|---|
| 1 | Set the flow path using the instructions under Method/Manual:FlowPath, Inlet, Outlet, AirTrap, Column. |
|---|---|

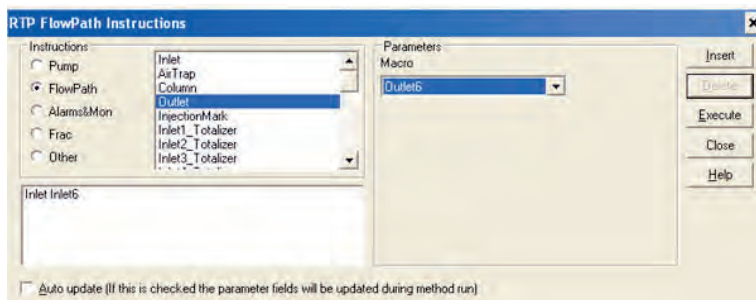

- | | |
|---|---|
| 2 | Use an appropriate inlet and outlet, set AirTrap to Bypass and Column to Bypass . |
| 3 | Connect the inlet tubing to appropriate buffer vessels. |
| 4 | Start pump A (%B = 0) with a ManFlow of 50%. |

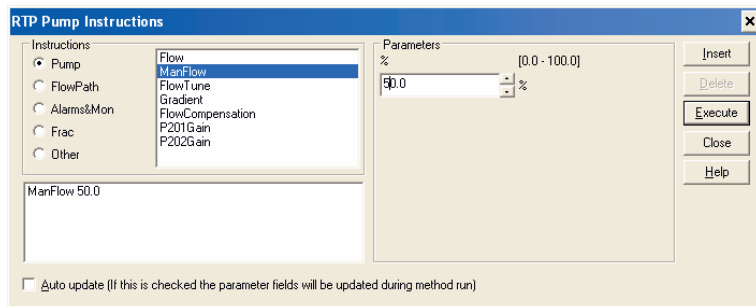

- | | |
|---|---|
| 5 | Run the pump until the flow meter signal is stable. |
| 6 | Start pump B (%B = 100) with a ManFlow of 50%. |
| 7 | Run the pump until the flow meter signal is stable. |

Calibration

Step	Action
------	--------

- | | |
|---|--|
| 1 | For calibration, set Flow to at least 20 l/h for LowFlow Kit and 40 l/h for HighFlow Kit. |
|---|--|

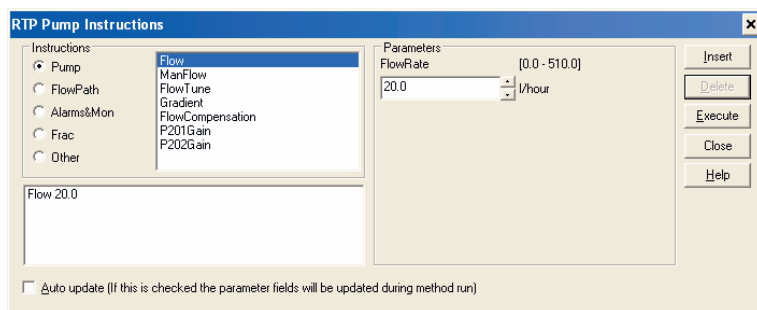

- | | |
|---|--|
| 2 | Set Column under FlowPath to Inline . |
| 3 | When flow signal is stable at set flow rate, select P201Gain under Pump and press Execute . |

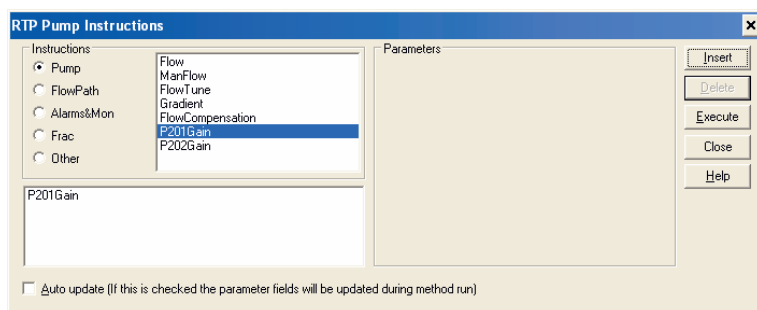

- | | |
|---|---|
| 4 | Set Gradient under Pump to 100%B and wait for a stable flow signal. |
|---|---|

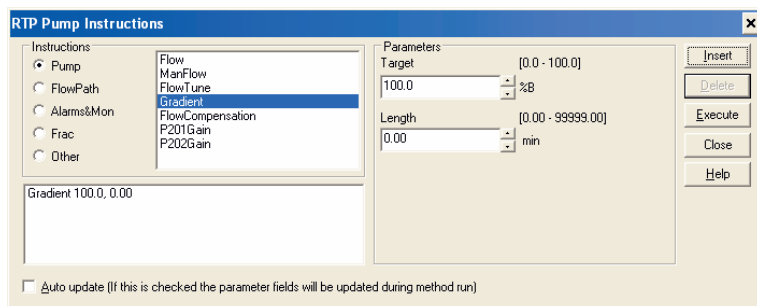

7 ÄKTA ready gradient

7.3 Calibrate and operate the ÄKTA ready gradient pump

Step Action

- 5 Select **P202Gain** under **Pump**, press **Execute** when flow signal is stable at set flow rate.

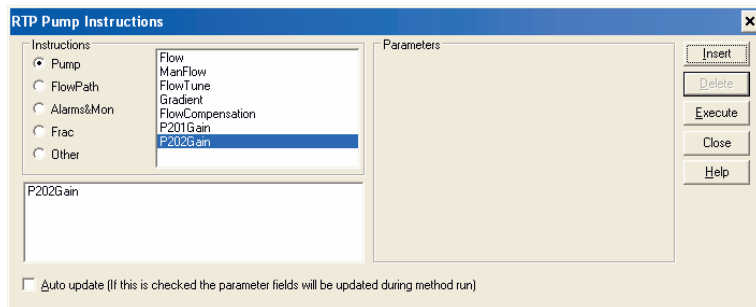

- 6 Select **FlowCompensation** under **Pump** to **ON** and let the calibration procedure compensate for differences between the capacity of pumps A (**P-201**) and B (**P-202**).

Note:

FlowCompensation is default set to OFF and has to be activated in each run.

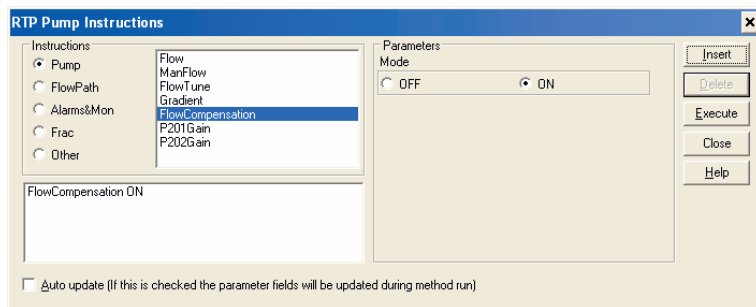

8 Component test

About this chapter

This chapter describes the component test, which should always be run after installing a new flow kit to secure the functionality of the different flow cells. The structure and content of a component test report is presented, and troubleshooting after a failed test is discussed to secure the functionality of the different flow cells.

Precautions



WARNING

Before attempting to perform any of the procedures described in this chapter, you must read and understand all contents of the corresponding section(s) in the [Section 2.1 Safety precautions, on page 16](#), as listed below:

- [General precautions, on page 16](#)
- [Flammable liquids and explosive environment, on page 17](#)
- [Personal protection, on page 18](#)
- [Operation, on page 21](#)

In this chapter

This chapter contains the following sections:

Section	See page
8.1 Run a component test	112
8.2 The test report	117
8.3 Troubleshooting a failed component test	120

8.1 Run a component test

General

The component test consists of a number of steps to assure correct function of the components of the ÄKTA ready, in particular the sensors. The points being tested are:

- Function of flow meter and size of flow kit.
- Function of UV and conductivity sensors.
- Function of pressure sensors.

Note: *A component test should always be performed after mounting a new flow kit.*

The component test is included in the flow kit installation wizard.

What does the test do?

Stage	Description
1	Initially in the component test, a number of settings are made. Inlets are opened and primed and pressures are set to zero.
2	Stray light calibration is performed. Stray light calibration shuts off the UV LED lamp for approximately 10 seconds. During this time, stray light from the outside is measured. The measured light is later subtracted from the UV measurements made during the run. Note: <i>Do not change anything on the system or in UNICORN during the time (approximately 10 seconds) stray light is being measured. Also note that if stray light calibration is included in a user-defined method, a delay of at least 0.3 minutes is required before the next instruction.</i>
3	After the air trap has been filled with the chosen liquid, the function of the flow meter cell is tested — if the test fails, the test procedure will stop.
4	Next, the size of the flow meter cell is tested. If the selected component does not match the actual component mounted on the system, the test procedure will stop.
5	UV and conductivity test is performed by pumping a solution of 1% (v/v) acetone and 1.0 M sodium chloride through the flow kit and the actual flow cells. If the response is within specifications for both flow cells the test will pass, otherwise the test will fail for one or both flow cells.
6	Finally, the component test checks that the three pressure sensors are working and that they produce acceptable pressure readings.

Stage	Description
After:	After the test has finished, the test results can be printed. The results printout shows all registered flow kit bar codes, installation procedures, notes, and test results. If page 8 does include any warning or other text the test failed. If all flow cell tests passed the system can be used.
Failure:	If any part of the test fails, there is a troubleshooting guide available (see Section 8.3 Troubleshooting a failed component test , on page 120).

Prepare a test

Wash liquid and test solution are required for a component test. A *Test solution preparation protocol* template is available on the system CD. The volumes depend on the flow kit used:

- ÄKTA ready High Flow Kit — 25 liters of wash liquid and 10 liters of test solution.
- ÄKTA ready Low Flow Kit — 10 liters of wash liquid and 5 liters of test solution.

Test solution for the High Flow Kit is prepared as follows: 10 liters of 1.0 M NaCl with 1% acetone in purified water (i.e., 584 g NaCl + 100 ml acetone in 9.90 liters purified water). For the Low Flow Kit, half the amounts are used.

Note: *The test solution should be freshly made, so the acetone does not evaporate.*

Step	Action
------	--------

- | | |
|---|--|
| 1 | Remove the protective end cap from inlet 6 (arrow), and connect the wash liquid. |
|---|--|

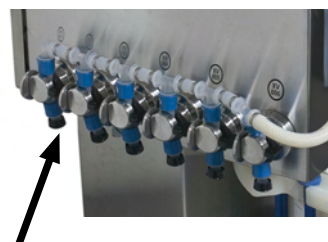

Note:

Containers must not be placed at a level lower than 1 m below the inlets (i.e., floor level).

8 Component test

8.1 Run a component test

Step	Action
------	--------

- | | |
|---|---|
| 2 | Remove the protective end cap from inlet tube 5 (arrow), and connect the test solution. |
|---|---|

Note:

If ÄKTA ready gradient is installed use inlet tube 7.

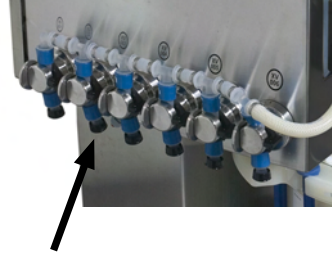

- | | |
|---|---|
| 3 | Remove the protective end cap from outlet 6 (arrow), and connect a waste hose to this outlet. |
|---|---|

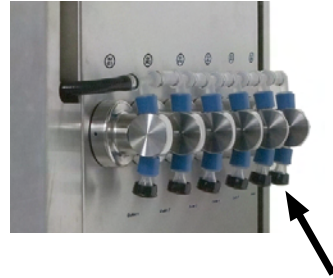

WARNING

Never block the outlet tubing with, for instance, stop plugs or any other device causing a pressure build-up, since this will create over-pressure and might result in injury.

Enter installation information

After pressing **Run** in the installation wizard, you are directed to the UNICORN start protocol with panels containing data about the installation.

Start Notes

In the first panel, **Start Notes**, is a text area where notes about the installation can be entered. Any notes written here will be included in the report.

Questions

The **Questions** panel has fields for entering product number and name, and identification data for the different parts of the flow kit and the pH electrode (if used), There is also a field for the test solution protocol number.

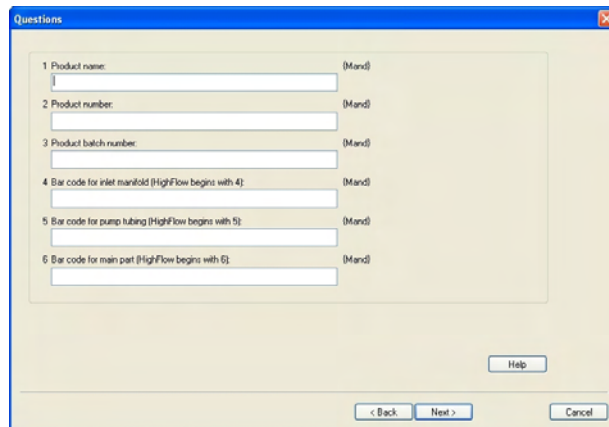

Much of the information can be conveniently scanned in using the supplied bar code scanner. It can also be manually entered. The information supplied will be included in the report.

Result name

The panel **Result Name** contains fields for the name of, and path to, the result file, where results will be stored. Enter a proper name for the result file, in other case it will get the name "Wizard generated" and you may end up with a lot of such files with the same name.

The **Result Name** panel also has a **Start** button. When finished entering data, press the **Start** button to start the test.

Running the component test

A component test takes approximately 10 minutes. The progress of the test can be followed in UNICORN, in charts showing the response curves for different sensors.

During the run, two things will happen that will require user attention:

- A short while after the test has started, a warning message will appear on the screen saying that UV stray light reduction is activated. This warning message is information only and requires no action from the user. The test will proceed normally regardless of if the user closes the message box (by pressing the **Acknowledge** button), or not. The warning message can be disabled, see [Manual calibration of UV stray light, on page 149](#).
- A while into the test, a message will appear prompting the user to fill the air trap. This message requires user action: Press the **AIR VENT** button to open the air vent valve (**HV-301**), allowing for evacuation of air from the air trap.

Note: *You must respond to the message regarding evacuation of the air trap. If the air trap is not properly filled, the test may fail.*

Any time during the test run it is possible to manually add run notes that will be included in the report. The notes dialog is opened by selecting **View:Documentation** in UNICORN.

8.2 The test report

General

Information about an installation including the results from the component test are stored and can be compiled into a printed report.

If the option **Print report automatically** was chosen initially in the installation wizard ([Open the installation wizard, on page 88](#)), the results from the component test run will be available in the form of a printed report produced immediately after the test has finished.

If the option **Print report automatically** was not chosen, a printed report can be created at a later time by selecting **AKTA ready_FlowKit** under **File:Report** in the UNICORN Evaluation module.

What does the report contain?

A flow kit installation report in **AKTA ready_FlowKit** format, including component test results, contains the following parts (in the order they occur in the printed document):

Header

A header containing basic information is shown at the top of each report page. The information includes the UNICORN version number, the name of the person who ran the test, and the time and date for the test. Also the path for the result file is shown in the header.

Questions

The **Questions** section contains identification information. This is the same information as that entered in the **Questions** panel in UNICORN, i.e. product name and number, barcodes for flow kit parts and pH electrode, protocol for test solution preparation, and the mode for entering codes.

Method notes

The **Method notes** section contains the name of the system, and a list with the different steps that were taken when installing the flow kit. The steps are the same, and in the same order, as the steps in the installation wizard.

Start notes

Start notes include any notes entered before starting the test run in the start protocol.

Run notes

Run notes include any notes/comments entered during the test run.

Evaluation notes

Evaluation notes are notes entered after the test is finished by selecting **View:Documentation:Notes** in UNICORN Evaluation module.

Results from component test

The section **Results from component test** contains the test results. The results are presented in the form of charts showing the response over time for each of the different sensors. An example page is shown in the figure below.

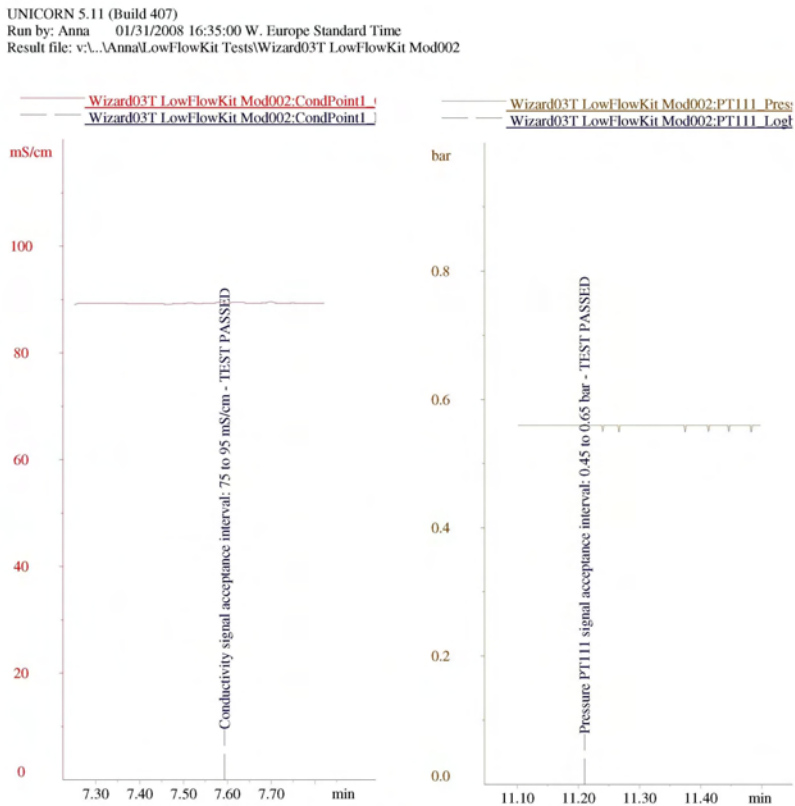

A vertical text on each chart shows the acceptance interval used and also whether the component in question passed the test or not.

If the test for a component fails, troubleshooting should be done; see [Section 8.3 Troubleshooting a failed component test](#), on page 120.

Last page

The last page of the report has the header **Comments**, under which there is room for comments on the paper copy of the report. The page also contains the signature fields **Performed by** and **Approved by**, where date, name and position can be specified.

8.3 Troubleshooting a failed component test

Troubleshooting

Should a component fail the component test, troubleshooting should be done to establish the cause of failure and allow for correction of the problem. A failing component is identified in the report or result file by the text **TEST FAILED** in the component chart.

Troubleshooting is easiest done using **Troubleshooting** in the installation wizard. The troubleshooting wizard finishes with an additional component test, identical with the section previously described.

Open the installation wizard

To open **Troubleshooting** in the installation wizard, select **File:Instant Run...** in the UNICORN System Control module and press **Run** in the dialog shown. In the wizard, select **Troubleshoot Failed Component Test**. Select which components to troubleshoot by checking one or more of the checkboxes shown.

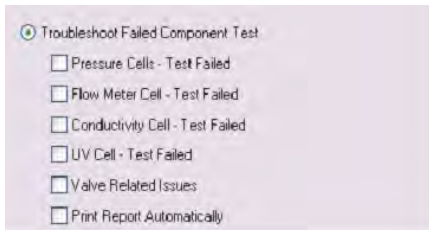

Pressure sensors

The most likely reason for pressure sensors to return incorrect values is incorrect mounting:

- Make sure that each flow cell is properly aligned with its adapter. Check that there is no gap between flow cell and adapter. If necessary, loosen the screws and remount the cell according to the instructions in [Mount the main part tubing, on page 95](#). The screws holding the latch pressing the flow cell against the adapter should be firmly tightened (using finger force).
-

Flow meter

Problems with incorrect flow meter readings can be caused by:

Problem	Solution
Transducer surfaces not treated with Vaseline.	Make sure Vaseline has been applied to the contact surfaces of the transducer connectors (see Mount the main part tubing, on page 95).
Incorrectly mounted pump tubing.	Check that the pump tubing has been correctly mounted, and that the pump lid is properly secured. Make sure the pegs on the pump lid are turned all the way down (see Connect and mount the pump tubing, on page 93).
Poor pump tubing connection.	Make sure the TC clamps connecting the pump tubing to the main part of the flow kit, and to the inlet tubing are properly connected and that the TC gaskets are in right position.
Cavitation (small air bubbles produced by under-pressure), which results in unstable flow meter readings. Cavitation is recognized by a hissing noise.	

Conductivity

Problems with conductivity can be caused by:

Problem	Solution
Poor connection.	Make sure the conductivity sensor's connector cable is properly connected to the system cabinet (see Mount the main part tubing, on page 95).
Wrong inlets used.	Check that the wash liquid is connected to inlet 6 and the test liquid to inlet 5 .
Wrong composition of wash liquid and/or test solution.	Make sure that the liquids used are fresh and correctly prepared (see Prepare a test, on page 113).
Errors in temperature readings.	<p>Conductivity is temperature compensated and thus dependent on correct temperature readings. The temperature window is located on the back of the flow meter cell (see Mount the main part tubing, on page 95). Possible problems with temperature measurement are:</p> <ul style="list-style-type: none"> • Loose flow meter cell. Check that the flow meter cell is properly snapped onto its mounting knobs (see Mount the main part tubing, on page 95). A gap between the temperature window and the sensor may cause incorrect measurements. • Dirty or damp temperature window. Wipe clean with soft tissue. • System temperature not stable with respect to surroundings. If room temperature changes or if the system is moved from one room to another, it must be given time to adjust to current room temperature. • Make sure the temperature of the process liquid not differs more than 10°C from ambient temperature.

UV

Problems with UV can be caused by:

Problem	Solution
Insufficient light transmission.	Check that the UV cell and sensor windows are clean and dry. Wipe with soft tissue if necessary.
Incorrect mounting of UV cell.	Make sure that the UV cell is pushed all the way in.
Wrong inlets used.	Check that the wash liquid is connected to Inlet 6 and the test liquid to Inlet 5 .
Wrong composition of wash liquid and/or test solution.	Make sure that the liquids used are fresh and correctly prepared (see Prepare a test, on page 113).
Condensation of moisture on the flow cell window.	Make sure the temperature of the process liquid not is lower than 10°C from the ambient temperature.

Valves

Problems with valves can be caused if:

Problem	Solution
Valve safety lock not closed.	<p>To close an open valve safety lock:</p> <ol style="list-style-type: none"> 1 Switch the Installation switch (in upper, right corner of cabinet front; see Components on system cabinet – front, on page 43) to position FLOW KIT INSTALL. 2 Close the safety lock by turning the handle 180 degrees (see Finishing flow kit installation, on page 99). 3 Turn the installation switch back to RUN. <p>Note: <i>FLOW KIT INSTALL may fill all parts of the flow kit with fluid from the air trap, also inlet and outlets that are currently not used. To avoid spillage of liquid, do not remove the end caps from connections that are not used.</i></p>
Tubing not properly inserted.	<p>If part of the tubing has not been properly inserted in a valve:</p> <ol style="list-style-type: none"> 1 Turn the Installation switch to position FLOW KIT INSTALL. 2 Open the valve lock. 3 Insert the tubing. 4 Close the valve lock. 5 Turn the installation switch back to RUN.

If problems remain

If problems continue after checking the points above, please contact your GE Healthcare representative (contact information on back cover).

9 Column installation

About this chapter

This chapter describes how to install a column on the ÄKTA ready. Much of the information in this chapter is available under **Column Installation** of the ÄKTA ready installation wizard (part of supplied software).

The chapter also contains instructions for running an efficiency test and for column rinsing. Both are optional procedures that can be performed in connection with installing a new column. Note that ReadyToProcess columns are factory tested and are supplied with a certificate stating the results from an efficiency test performed on the individual column.

Precautions



WARNING

Before attempting to perform any of the procedures described in this chapter, you must read and understand all contents of the corresponding section(s) in the [Section 2.1 Safety precautions, on page 16](#), as listed below:

- [General precautions, on page 16](#)
 - [Operation, on page 21](#)
-

In this chapter

This chapter contains the following sections:

Section	See page
9.1 Columns	127
9.2 Installing a column	130
9.3 Optional column test	137
9.4 Optional column rinsing	140
9.5 Adding columns to the column list	141

9.1 Columns

Column types

ReadyToProcess columns are recommended for use with the ÄKTA ready. Other types of columns may be used, but may require special safety precautions.

More information about columns and separation media can be found in the *Product catalog* on the GE Healthcare web page (address on back cover).

ReadyToProcess columns

ReadyToProcess columns are pre-packed, pre-qualified, and pre-sanitized chromatography columns. They are available with a range of BioProcess™ media, such as:

- Capto™ adhere
- Capto™ Core 700
- Capto™ DEAE
- Capto™ L (non-sanitized)
- Capto™ MMC
- Capto™ Q
- Capto™ S
- MabSelect™ (non-sanitized)
- MabSelect™ SuRe™
- MabSelect™ SuRe LX
- Butyl-S Sepharose™ 6 Fast Flow
- Blue Sepharose™ 6FF
- CM Sepharose™ FF
- DEAE Sepharose™ FF
- Phenyl Sepharose™ 6 Fast Flow (low and high sub)
- Q Sepharose™ FF
- SP Sepharose™ FF

ReadyToProcess columns are available in the following sizes:

- 1 l (i.d. 80 mm, bed height 200 mm)
- 2.5 l (i.d. 126 mm, bed height 200 mm)
- 10 l (i.d. 251 mm, bed height 200 mm)
- 20 l (i.d. 359 mm, bed height 200 mm)



Ordering information for ReadyToProcess columns is found in [Section 14.4 Ordering information, on page 211](#). RTP columns packed with Capto and Sepharose 6FF media can be requested by GE Healthcare even if not listed in ordering list.

ReadyToProcess columns are qualified by efficiency testing and are delivered with individual certificates. Testing includes for example analysis of theoretical plates per m packed bed (N/m) and asymmetry factor (A_s).

Other columns

Although ReadyToProcess columns are recommended for use with ÄKTA ready, other columns may be used provided they are capable of withstanding maximum system pressure. If not, separate pressure safety devices must be used.



WARNING

High pressure. The flow rate may under no circumstances exceed the specified column maximum flow rate. High flows might affect the packed medium, causing the pressure to exceed the specified column maximum pressure.



WARNING

Over-pressure. Use columns that withstand expected pressures. If not, the columns might rupture, resulting in injury.

Contact GE Healthcare for more information about using products other than ReadyToProcess columns with ÄKTA ready.

9.2 Installing a column

Introduction

The steps described in this section follow the steps in the **Column Installation** trail in the ÄKTA ready Installation Wizard. Refer also to the information provided in the instructions for the chosen column.

Preparation

Before installing a column, the flow kit must be filled with liquid (e.g., distilled water) from **inlet 6** to the column valves, including the air trap. If the column is installed after a component test, the flow kit is automatically filled and no further preparation is necessary.

Open the column installation wizard

Open the **Column Installation** trail of the ÄKTA ready Installation wizard by selecting **File:Instant Run...** in the UNICORN System Control module, and then **Run** in the dialog shown. In the window displayed, select **Column Installation**.

If you intend to run a column test or a rinsing program, also check the **Include Efficiency Test of Column** box and/or **Include Rinsing of Column**. (Column testing is discussed in [Section 9.3 Optional column test , on page 137](#) and rinsing in [Section 9.4 Optional column rinsing , on page 140](#).)

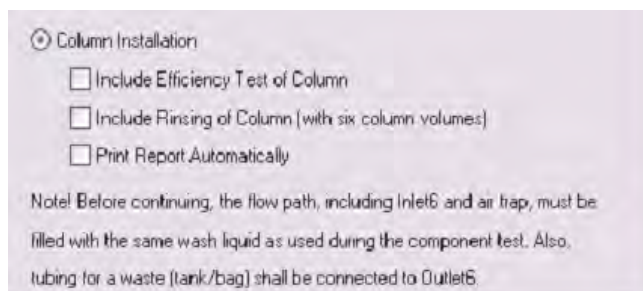

Select **Print Report Automatically** if you want to automatically produce a printed report with installation information and test results. A printed report can also be produced at a later time, under **File:Report** in the UNICORN System Control module.

Similar to the wizard for installing a new flow kit, the column installation wizard contains checklists with actions to be performed. Each action is confirmed by checking the corresponding **Completed** box in the wizard.

Select a column type

The first panel of the column installation wizard is **Initial settings**. The **Initial settings** panel contains fields for selecting a column type.

Step	Action
------	--------

- | | |
|---|---|
| 1 | From the Technique drop-down list in the Initial settings panel, select a chromatographic technique from the alternatives: All , Affinity , Anion exchange , Cation exchange , and Hydrophobic Interaction . The selection limits the list of columns available for selection in next step. Default is All , which means the list will include all columns available, regardless of technique. |
|---|---|

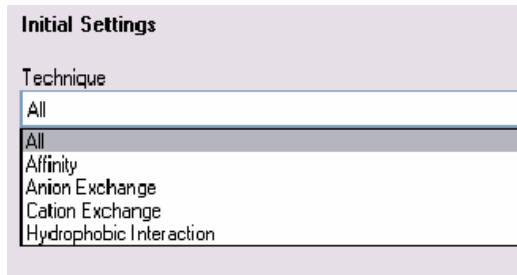

Step **Action**

- From the **Column** drop-down list, select the column type that will be used. The list is limited to columns relevant for the technique selected in the previous step. If **All** was selected, the list will include all columns available, regardless of technique.

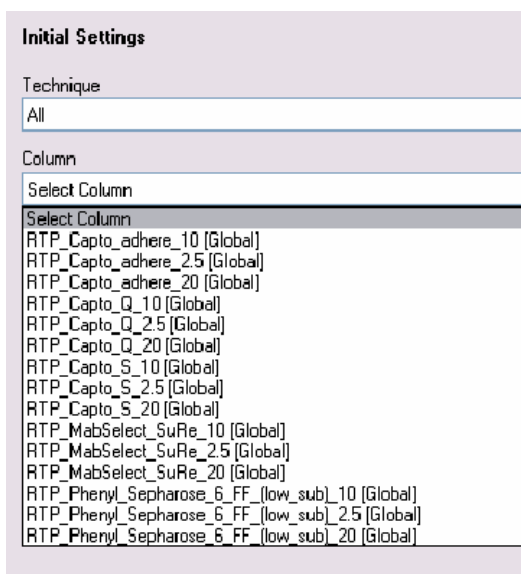

- Prepare a column of the selected type and place it on the column trolley. Position the column so that the column's inlet tubing, marked **Bottom Inlet**, is facing the handle of the column trolley. Roll the trolley into position between the system cabinet leg supports, and lock the trolley wheels.

Note:

Be careful when transporting smaller columns (e.g., 2.5 l) on the trolley. Small columns are light and have a narrow base, and may therefore be unstable.

- Press **Next** in the column installation wizard. This will open a checklist of actions for connecting the column.

Connect a column



CAUTION

Before use, check that the column is not damaged or otherwise defective. Damaged or defective columns may leak.

Follow the instructions below to connect a column to the system (connectors should be treated aseptically when connecting):

Step	Action
------	--------

- | | |
|---|--|
| 1 | Remove the welded tubing end from the Bottom Inlet tubing on the column (keep the tubing ends for when the column shall be sealed). |
|---|--|

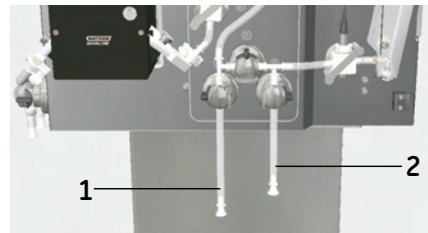

- | | |
|---|---|
| 2 | If necessary, fill the inlet tubing with 20% Ethanol, using e.g. a squirt bottle. |
|---|---|

- | | |
|---|---|
| 3 | Remove the protective end cap from the column outlet tubing on the flow kit (1 in figures) and, using a TC clamp, connect it to the Bottom Inlet tubing on the column. |
|---|---|

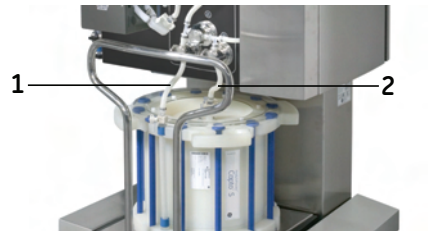

- | | |
|---|---|
| 4 | Repeat the steps above for the Column outlet connector (2 in figures): |
|---|---|

Connect this tubing to the **Top Inlet** tubing connector on the column.

Finish the installation

- | Step | Action |
|------|--|
| 1 | Turn the Installation switch in the upper, right corner of the system cabinet to the COLUMN INSTALL position. This will open a free passage from air trap to column. |
| 2 | Let liquid drain from the air trap down to the column. Release under-pressure in the air trap by pressing the AIR VENT button next to the air trap release valve (HV-301). If necessary, tap, flick or squeeze the tubing (arrows in figure) until it is completely filled with liquid and no more bubbles enter the air trap. |
| 3 | Turn the Installation switch in the upper, right corner of the system cabinet to the RUN position. |

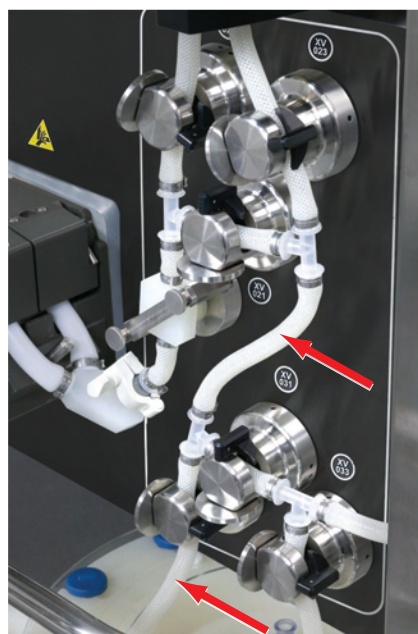
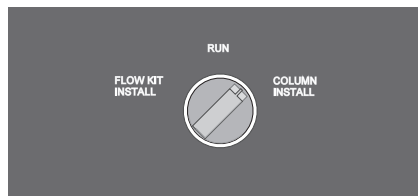

After the column installation wizard has finished, UNICORN displays the start protocol with information about the installation, and input fields for parameters specifying the current setup.

The input fields are the same as those for a flow kit installation, as discussed in [Enter installation information, on page 115](#), with one exception: There is an additional field for the column's identification number. Similar to the other identification numbers, this number can be scanned using a hand scanner, or it can be entered manually.

9 Column installation

9.2 Installing a column

A report similar to the flow kit installation report can also be produced for a column installation. The report can be either automatically produced, or manually created by selecting the report format **AKTA ready_Column** under **File:Report** in the UNICORN Evaluation module. The report format **AKTA ready_Column_T** also contains results from an efficiency test; see next section.

9.3 Optional column test

Introduction

A method for efficiency testing of columns can be created in the UNICORN method editor (from the provided method template), or an efficiency test can be run in connection with installation of a column, using the installation wizard, as described in [Section 9.2 Installing a column, on page 130](#). Efficiency testing using the wizard places the test results in the column installation report.

Column efficiency testing, when included in the column installation, should be performed under stable conditions, in room temperature, using the flow rates, volumes, and buffers prescribed. Test results are presented in the installation report.

Note: *ReadyToProcess columns are already qualified by efficiency testing and delivered with individual certificates. Customized methods for efficiency testing of other columns can be created using the supplied wizard; see [Section 10.3 Creating a column efficiency test, on page 169](#).*

Preparations

When selecting the **Column Installation** alternative in the column installation wizard, the user is given the choice of also checking the **Include Efficiency Test of Column** box (see [Section 9.2 Installing a column, on page 130](#)). By doing so, additional items concerning preparation and connection of wash and test liquids will be included in the wizard's checklists.

The liquids required for the test are:

- Column wash liquid — A tank with purified water connected to **inlet 6**. The volume required is shown in the wizard. The volume depends on the size of the column.
- Tracer solution — A tank with 5 l solution of 2% acetone in column wash liquid, connected to **inlet 5**.

Note: *If test results are to be compared, use the same solvent for wash and test liquids. The wizard recommends using either water or 20% ethanol. The choice of solvent will affect test results, ethanol will produce lower values compared to water.*

Running the column efficiency test

A column efficiency test is started by pressing **Start** in the UNICORN **Result Name** panel in the **Start Protocols** dialog displayed immediately after finishing the installation wizard. The test is performed using 100 cm/h liquid velocity and normally takes approximately 30 minutes. Similar to a component test, it is possible to enter notes during the test (see [Running the component test, on page 116](#)).

For more information about efficiency testing of columns see the application note *Efficiency test of ReadyToProcess columns* (see [Section 1.3 Associated documentation, on page 14](#)).

Test results

Results from an efficiency test are stored and processed in a similar way as results from a component test. The results are stored at a user-defined location, and they can be compiled and presented in the form of a printed report using report format **AKTA ready_Column_T**, which includes results from the efficiency test in addition to the installation information in report format **AKTA ready_Column**.

In addition to the general information, a column test report also contains detailed information about the column used (e.g., volume, technique, max and default flow rates, etc.).

A column test report contains a chart showing the peak in UV response caused by the progressing pulse of tracer solution, together with suggested acceptance criteria.

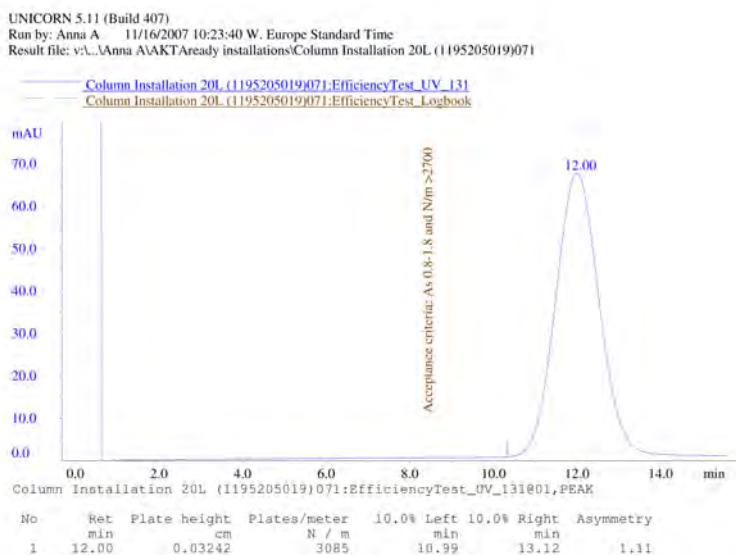

Note: Unlike a component test report, a column test report does not state whether a column has passed or failed a test. Instead, it is the responsibility of the user to compare the test results with provided acceptance criteria in order to decide if the test was successful or not.

9.4 Optional column rinsing

Column rinsing

A method for column rinsing may be custom designed by the user, or the predefined method for column rinsing can be used. The predefined method is included as an optional step in the column installation wizard.

Column rinsing is performed with 6 column volumes to remove all remaining storage solution or tracer solution from the column.

Preparations

If column rinsing was selected in the installation wizard (i.e., **Include Rinsing of Column** was checked) the wizard will include a field for selecting the inlet used for the rinsing liquid.

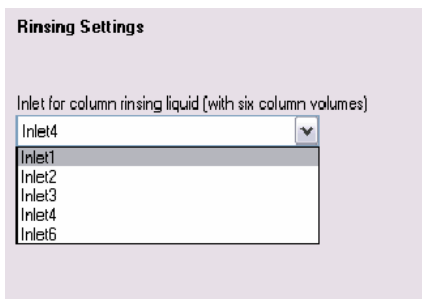

The rinsing liquid may consist of, for instance, purified water or a low salt buffer (see column documentation for details). The volume required depends on the column used. Note that the liquid used for rinsing may be the same as that used as wash liquid in a previous efficiency test (see [Section 9.3 Optional column test, on page 137](#)). In such case, the same inlet is selected.

Run the rinsing procedure

Column rinsing takes approximately 80 minutes. No actions from the user are required during this time. It is possible to enter notes during a run.

9.5 Adding columns to the column list

Adding columns

It is possible to add columns, for example “RTP columns on request”, to the ÄKTA ready installation wizard. Follow the steps below to add a new column to the UNICORN column list.

Instruction

- | Step | Action |
|------|--|
| 1 | Open the Column List dialog in the Edit menu in the Method Editor module. |
| 2 | Select a column supported by the ÄKTA ready software (i.e. a ReadyTo-Process column with the prefix “RTP” in the list), that has the same column volume and average particle diameter as the column to be added (marked items in figure). This will set the advanced parameters that are compatible with the software. |
| 3 | Press Edit for the selected column. |
| 4 | Enter appropriate parameter values for the column to be added (Max pressure , for instance, depends on the type of medium). |
| 5 | Press Save As... (marked in figure) to save the column with a new name. Save as global only if the column is to be available to other users (e.g., on a network). |
| | <p>Note:</p> <p>Do <u>not</u> press Save! If a column is edited and Save is pressed, the edited parameters will be overwritten.</p> |
| 6 | The added column is now be available in the ÄKTA ready wizard. |

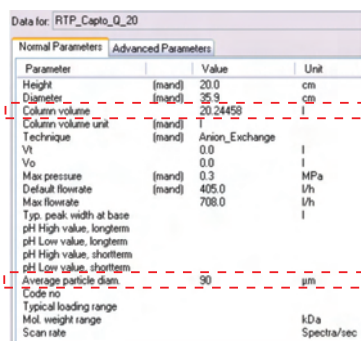

10 Creating a method

About this chapter

This chapter describes how to create a method for ÄKTA ready in the UNICORN **Method Editor**. In a simple example the general structure of a method is shown, along with the different steps required to create it. There is also a section discussing the wizard for creating test methods for efficiency testing of columns.

Note that the discussion in this chapter applies to methods written for the ÄKTA ready strategy. For information about methods in general, and for detailed information about the **Method Editor**, please see the UNICORN manuals.

Courses in UNICORN system control, including method design, are available from Fast Trak Training & Education. Contact your local GE Healthcare representative for information.

In this chapter

This chapter contains the following sections:

Section	See page
10.1 The Method Editor	143
10.2 An example of using the Method Editor	153
10.3 Creating a column efficiency test	169

10.1 The Method Editor

In this section

This section contains the following subsections:

Section	See page
10.1.1 Introduction to the Method Editor	144
10.1.2 Method Editor layout	146
10.1.3 Other Method Editor features	148

10 Creating a method

10.1 The Method Editor

10.1.1 Introduction to the Method Editor

10.1.1 Introduction to the Method Editor

Description

The **Method Editor** is used to build new methods in a step-by-step manner using blocks and instructions as building elements. The editor can also be used to edit already existing methods.

Blocks

About blocks

Blocks are used to organize instructions into functional units. A block may, for instance, contain instructions for loading a sample, or for equilibrating a column. Blocks can be nested (i.e., a block can contain other blocks).

Blocks are useful for organizing instructions and structuring methods, and also allow for reuse of existing sets of instructions. Individual blocks can be moved and used in any method (within the same strategy) as required.

Creating a block

The general procedure to create a block in the **Method Editor** is to:

- 1 Select **Block:New...** from the menu.
 - 2 In the dialog shown, give the block a name and select a base (**Time**, **Volume**, or **Column volumes**) for the block. The choice of base depends on the function of the block.
 - Use **Time** as base for valve and pump maneuvering
 - Use **Volume** for sample application or fractionation.
 - Use **Column volumes** for blocks used for equilibration and washing.
-

Opening the Method Editor

Open the **Method Editor** window from the UNICORN **Manager** module by selecting it in the task bar at the bottom of the screen.

Step	Action
------	--------

- | | |
|---|---|
| 1 | Click on the Customize panes icon in the Method Editor toolbar. |
|---|---|



- | | |
|---|---|
| 2 | Select Text and Instruction box in the Customize panes dialog shown. |
|---|---|

- | | |
|---|-------------------|
| 3 | Press OK . |
|---|-------------------|

The upper part of the **Method Editor** window now shows the **Text pane** and the lower part by the Instructions box. It is possible to also show an optional flow diagram, or a block diagram in the **Method Editor**, by selecting the appropriate items in the **Customize panes** dialog. These diagrams can help when programming advanced methods, but are not required for building or editing a method. They are therefore not included in the following discussion.

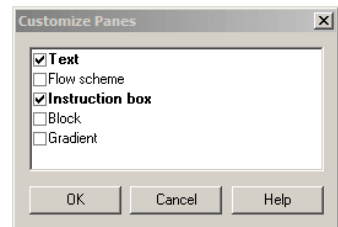

10.1.2 Method Editor layout

Text pane

The **Text pane** contains an overview of the method in the form of an expandable list with all blocks and instructions in the method. Blocks are marked by blue square symbols. The figure to the right shows a method with several blocks and instructions. For a newly created method, only the **Main** block is shown, with a defined **Base**.



The list in the **Text pane** has a tree structure and individual blocks can be expanded or contracted, as indicated by the + or - signs. When expanded, all the block instructions and nested blocks are displayed and available for editing.

Editing is done in the **Instructions box** in the lower part of the **Method Editor** window.

Instructions box

The parameters for the block or instruction that is currently selected in the **Text pane** are displayed and available for editing in the **Instructions box** in the lower part of the **Method Editor** window.

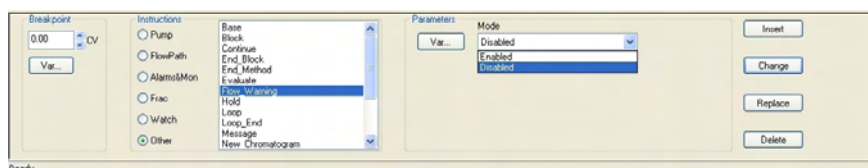

The **Instructions box** is divided into four areas. These are, from left to right:

- **Breakpoint** – Contains a field for setting the breakpoint for the instruction or block, in the unit currently selected as base (the base can be **Time** or **Volume**).
- **Instructions** – Contains controls for selecting an instruction from a list. The instructions available are grouped according to function. Groups are selected using the radio buttons to the left of the list area.
- **Parameters** – Contains parameter fields for the chosen instruction. The parameters will vary between the different instructions.

- Buttons — There are four buttons: **Insert**, **Change**, **Replace**, and **Delete**. **Change**, **Replace** and **Delete** affect the instruction or block currently selected in the **Text pane**. While **Insert** adds a new instruction before, or after (if it has the same breakpoint as an old instruction), the current selection.

Note: *Changing the breakpoint of an instruction using **Change** will move not only the instruction itself, but also all subsequent instructions in the block. **Replace**, on the other hand, moves only the selected instruction.*

Instructions placed at the same breakpoint will execute simultaneously, while blocks will execute in the order they occur in the **Text pane**.

Changing valve positions, or changing the speed of the pump does not take place momentarily, but requires a small amount of time. A small time lag, such as 0.10 min, should therefore be introduced after time-based instructions affecting mechanical components.

Note: *There is no undo-function in UNICORN and you are therefore recommended to regularly save the method you are working with, preferably using different version numbers.*

10.1.3 Other Method Editor features

Introduction

The method created in the following chapter covers the most basic aspects of how a method is built. Follow this example to learn the basics of designing a filtration method. A few useful features demonstrated in this example are briefly described here.

Variables

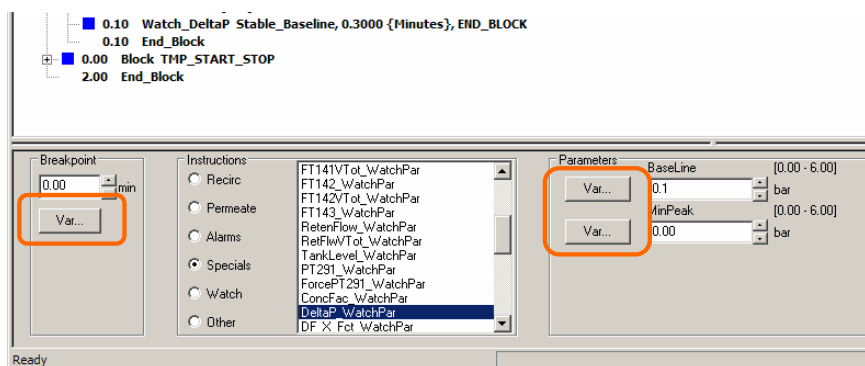

There is one **Var...** button in the **Breakpoint** field and a one **Var...** button for each parameter in the **Parameter** field.

These are used to create variables representing breakpoints or parameters. Variables enables re-use of defined breakpoints and instructions in other blocks.

UV stray light calibration

There is an instruction to perform a stray light calibration. When a new flow kit is mounted the instruction is activated automatically via the installation wizard. It may also be included in the methods if so needed.

The instruction **StraylightCalib_UV_AT_131** is available in the **Instructions box** under group **Alarms&Mon** and is used for a manual calibration.

Manual calibration of UV stray light

When the stray light calibration is performed a warning message is displayed. The warning message can be disabled.

Follow the instruction below to perform a UV stray light calibration.

Step	Action
------	--------

- | | |
|---|---|
| 1 | Select Alarms&Mon and then StraylightCalib_UV_AT_131 in the Instructions box . |
|---|---|

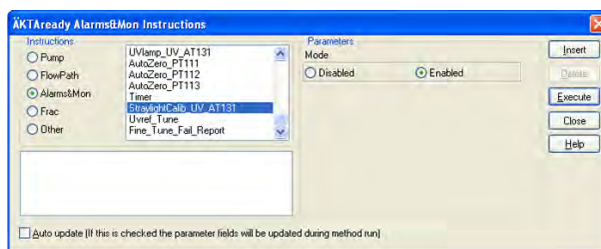

- **Enabled** is the default option. If you press **Execute** the stray light calibration will be performed and a warning message is displayed:
"Stray light reduction calibration. Do not perform any other instruction during the next 15 seconds."

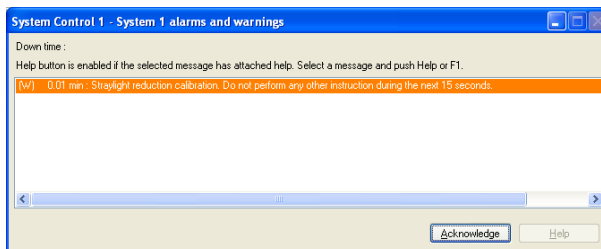

Press **Acknowledge** when 15 seconds have passed.

- If you select the option **Disabled** and after that **Execute** the stray light calibration will be performed without the warning message on the screen and without entry in the logbook.

10 Creating a method

10.1 The Method Editor

10.1.3 Other Method Editor features

Disable fine tuning flowmeter failed message

When the flow measuring algorithm fails to make a fine tuning of the flow measurement, a ***Fine_tuning_flowmeter_failed*** message is displayed. This is mainly a warning that the accuracy of the flow measurement is slightly decreased.

Step Action

- 1 Select **Settings...** on the **System** menu. Tick **Alarms&Mon** and scroll down to **Fine_Tune_Fail_Report**.

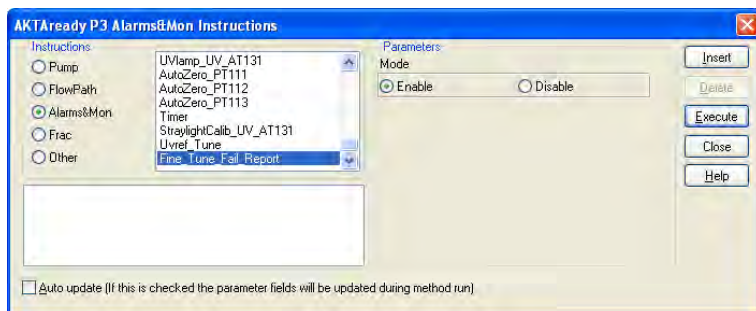

- If you select the option **Enable** and after that **Execute** the ***Fine_tuning_flowmeter_failed*** warning will be displayed if the system fails to perform a fine tuning.
- If you select the option **Disable** and after that **Execute** the ***Fine_tuning_flowmeter_failed*** warning will not be displayed on the screen and there will be no entry in the logbook.

Step	Action
2	<p>The report mode can also be changed only for the present run. After the run the setting is restored to the previous one.</p> <p>Select Alarms&Mon and then Fine_Tune_Fail_Report in the Manual menu.</p> <ul style="list-style-type: none"> • If you select the option Enable and after that Execute the Fine_tuning_flowmeter_failed warning will be displayed if the system fails to perform a fine tuning. • If you select the option Disable and after that Execute the Fine_tuning_flowmeter_failed warning will not be displayed on the screen and there will be no entry in the logbook.

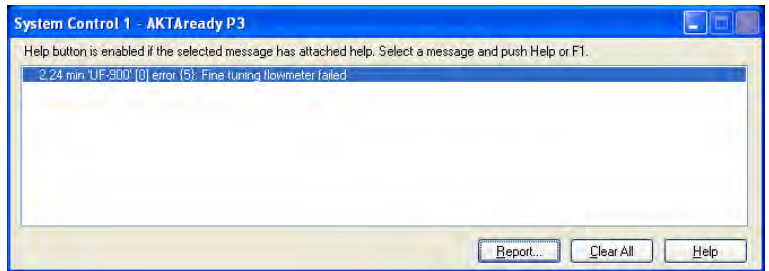

Totalizers

A totalizer monitors the accumulated volumes passing through an actual inlet or outlet. There are six inlet totalizers and six outlet totalizers. For each totalizer, there is a watch instruction allowing for easy programming of needed actions triggered by specific events.

To define an action based on the totalizer for, for instance, **Inlet 1**:

- 1 Enable the totalizer by inserting instruction **Inlet1_Totalizer** (under **FlowPath**) and setting it to **Enabled**.
- 2 Insert watch instruction **Watch_Inlet1_Totalizer** (under **Watch**) and set values for **Test** (e.g. **Greater_Than**), **Value** (volume in liters), and **Action** (e.g. **END_BLOCK**).

To activate an alarm for an enabled totalizer, insert the **Alarm_XXX_Totalizer** instruction (under **Alarms&Mon**) corresponding to the inlet/outlet in question. (Note that alarms automatically sets the system in pause mode.)

The allowed noise, or error, for a totalizer can be defined using the appropriate **WatchPar_XXX_Tot** instruction (under **Alarms&Mon**).

A totalizer can be reset to 0 liters by inserting an **XXX_Totalizer_Reset** instruction (under **FlowPath**).

10 Creating a method

10.1 The Method Editor

10.1.3 Other Method Editor features

Pressure flow control

Follow the instructions below to perform pressure flow control with optimal functionality.

Step	Action
1	Select PressureFlowControl and enable the function, then select PressureFlowLimit .
2	Select the pressure and the pressure sensor that should control the pressure.
3	Select the flow rate, and the pressure flow control will work as expected.
4	Deactivate the function and select a flow to change system status to flow mode.

10.2 An example of using the Method Editor

About the example

Creating a method involves creating and naming the method, and adding blocks and instructions to it. In this section, a simple example is used to illustrate the different steps in the procedure.

Note: *The method produced in this example is for training purposes only. It is not intended as an example of a production method.*

In this section

This section contains the following subsections:

Section	See page
10.2.1 Creating the method and selecting a column	154
10.2.2 Block 1: Opening valves	155
10.2.3 Block 2: Auto-zeroing pressure sensors	157
10.2.4 Block 3: Setting PID parameters	158
10.2.5 Block 4: Filling the flow kit	159
10.2.6 Block 5: Equilibration	161
10.2.7 Block 6: Sample load	162
10.2.8 Block 7: Washing unbound sample	164
10.2.9 Block 8: Elution	165
10.2.10 Block 9: Regeneration	167
10.2.11 Saving the method	168

10 Creating a method

10.2 An example of using the Method Editor

10.2.1 Creating the method and selecting a column

10.2.1 Creating the method and selecting a column

Start out by creating an empty method and selecting a column:

Step	Action
------	--------

1	Select File:New... in the Method Editor menu.
---	---

2	Click on the chosen system, select Method Editor , and click OK . The new method will show in the Text pane as a Main block with a Base definition (figure).
---	---



3	Click on the field named Columns in the Parameters area in the Instruction box . This field displays a popup list of available columns.
---	--

Select the RTP-column that is to be used, and press the **Change** button. (Note that ReadyToProcess columns start with "RTP" in the list.)

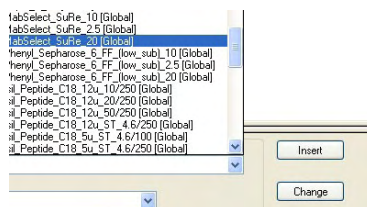

4	Set the Flow_Warning instruction to Disable and press the Insert button. This action will avoid repeated display of the warning message "No flow in beginning of method".
---	--

The flow warning will pop-up since inlet and outlet must be set before flow can be started. It is also crucial to use **Time** as base in this type of block, because if **Volume** is chosen and no pump instruction is used, nothing will happen.

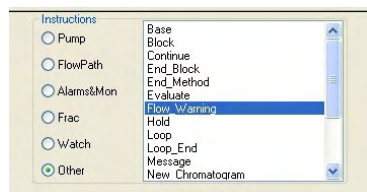

The column chosen is now displayed in the **Text pane** together with the instruction to disable flow warnings.

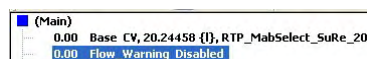

10.2.2 Block 1: Opening valves

The first block in the method will open valves in the flow path:

Step	Action
------	--------

- | | |
|---|---|
| 1 | Select Block:New... in the Method Editor menu. |
| 2 | In the New Block dialog shown, give the block a name, for example “MySetup”, and set the Base to Time .

The From: field under Call has the value Main (which is the only one available initially). |

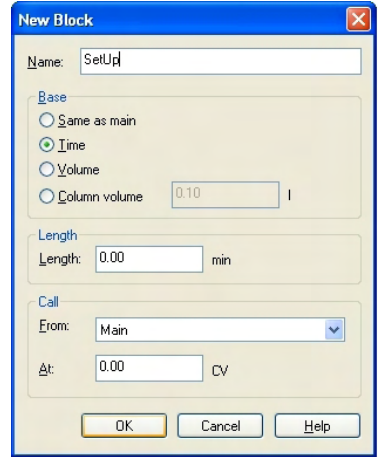

The new block will show up in the **Text pane** with the specified name and base.

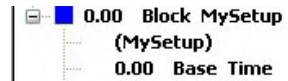

- | | |
|---|--|
| 3 | Insert an instruction that opens the valve for inlet 6: In the Text pane , select the Base instruction and, in the Instruction Box , set the Inlet instruction (under FlowPath) to Inlet 6 . The Breakpoint time should be 0.00. Insert the instruction into the block by pressing the Insert button. |
|---|--|

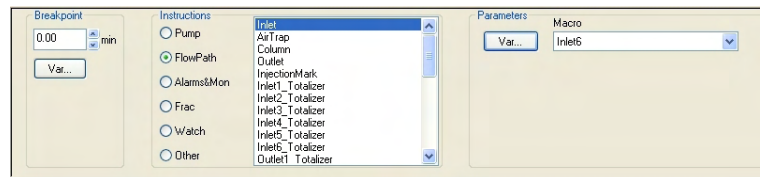

The new instruction will show up in the **Text pane** below **Base**.

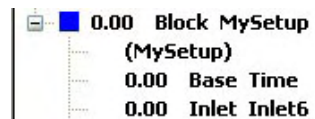

10 Creating a method

10.2 An example of using the Method Editor

10.2.2 Block 1: Opening valves

Step	Action
------	--------

4	Following the same general procedure as in step 3, insert also these instructions into the block:
---	---

- At time 0.10, set instruction **AirTrap** to **Bypass**.
- At time 0.20 set instruction **Outlet** to **Outlet6**.

The block is now finished. All the instructions are available for reviewing in the **Text pane** (see figure).

If you want to modify an instruction, select it and make the changes in the **Instructions box**.



10.2.3 Block 2: Auto-zeroing pressure sensors

Step	Action
------	--------

- | | |
|---|--|
| 1 | Follow the general procedure used for block 1 to create a new block. Name the block, for instance, "MyAutozeroPressure", and set its Base to Time . |
| 2 | Add instructions for auto-zeroing of the pressure sensors by inserting the instructions AutoZero_PT111 , AutoZero_PT112 , and AutoZero_PT113 (in group Alarms&Mon), at time 0.10. |

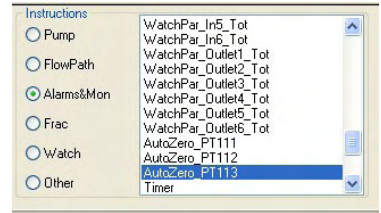

Note:

*This requires that the system is filled with air. If it is filled with liquid, the air trap valve has to be opened (by pressing the **AIR TRAP VENT** button with outlet closed and air trap inline).*

The **MyAutozeroPressure** block now contains three Autozero instructions, one for each pressure sensor.

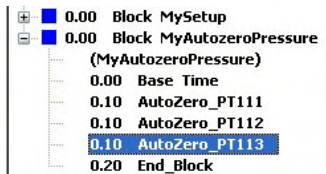

10 Creating a method

10.2 An example of using the Method Editor

10.2.4 Block 3: Setting PID parameters

10.2.4 Block 3: Setting PID parameters

Whenever an automated process step requires control of flow, the UNICORN control software employs PID-type controllers (see [Section 14.5 PID control, on page 215](#)). PID parameters are optimized to fit different column diameters. The default settings for the parameters are:

Column volume	P	I	D
1 l	0.3	25	0
2.5 l	0.3	25	0
10 l ¹	0.3	15	0
20 l ¹	0.5	10	0

¹ ÄKTA ready High Flow Kits should be used for columns of 10 l or more.

These settings provide fast response and robust control for most operating situations.

Step Action

- 1 Create a new block for setting of PID parameters. Name the block “MyPID-Parameters” and set **Time** as its base.
- 2 Insert the **FlowTune** instruction into the block. This instruction has the required fields for setting PID parameters.

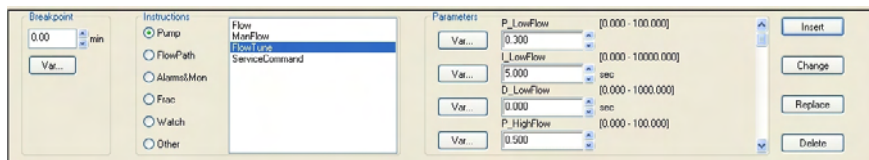

Note: There are six parameters in total, three each for the High Flow Kit and the Low Flow Kit. When running the method, only those parameters relevant for the flow kit installed are used.

The **PID_Parameters** block is a simple block, with the main content being the **FlowTune** instruction. Apart from this, the block only contains the required **Base** and **End_Block**.

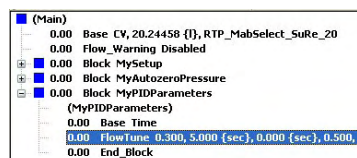

10.2.5 Block 4: Filling the flow kit

Next create a block for filling the flow kit, including the air trap, with liquid. This is done by pumping liquid through the flow path until a stable flow is achieved, or until a time-out (a maximum time) is reached.

- | Step | Action |
|------|--|
| 1 | Create a block named "MyFillFlowKit" and set its base to Time . |
| 2 | Add the instruction WatchPar_Flow_FT141 (in group Alarms&Mon), with parameters Delta_Peak and Delta_Base both set to 2.5 l/h. Since the test criterion used is based on flow stability, this sets an acceptable noise level for flow . |
| 3 | Insert the instruction Man_Flow (in group Pump), at time 0.00. The flow is set to 30%. The Man_Flow instruction will start pumping liquid through the flow path at a steady rate. |
| 4 | Define a Hold_Until instruction (in group Watch) at time 0.10. Set the Signal parameter to Flow_FT141 (refers to the flow meter), set the Test criterion to Stable_Baseline , and set Minutes to 0.5 (which means that the flow must remain stable for 0.5 minutes in order for the test criterion to be fulfilled).
Finally, set the Timeout to 5 minutes, and insert the instruction into the block. |

The screenshot shows the 'Parameters' dialog box for the 'Hold_Until' instruction. It contains the following settings:

- Signal:** Flow_FT141 (selected from a dropdown menu)
- Test:** Stable_Baseline (selected from a dropdown menu)
- Minutes:** 0.5 (with a range of [0.0 - 9999.0])
- Timeout:** 5.00 (with a range of [0.00 - 9999.90]) and a unit of min
- INFINITE:** Unchecked checkbox

Nested block: Filling the air trap

Create a separate block for filling the air trap. Make this a nested block, placed inside the **MyFillFlowKit** block.

- | Step | Action |
|------|--|
| 1 | Create a new block with the name " MyFillAirTrap ", and set its base to Volume . Set From:MyFillFlowKit instead of Main , and insert the block at time 0.40. The MyFillAirTrap block will now be placed inside MyFillFlowKit . |
| 2 | If not already selected, select the new block MyFillAirTrap in the Text pane to make it available for editing. |
| 3 | Set an AirTrap instruction to Inline and insert it at volume 0.0. |
| 4 | Insert a Man_Flow instruction with the flow set to 50% at volume 0.0. |
| 5 | Insert a Message instruction containing a message to the user that the AIR VENT button must be pressed in order to fill the air trap. Set the message to appear on Screen and add a Sound signal if so desired. |

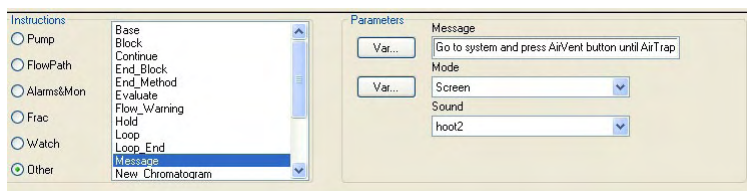

- 6 Set the **End_Block** instruction for the nested block at volume 2.50, which means that the block will finish when the pump has delivered 2.5 liters of liquid.

There is now a **MyFillFlowKit** block with a nested **MyFillAirTrap** block. The figure to the right shows both blocks expanded in the **Text pane**. Note that the nested block is based on **Volume** while the outer block is based on **Time**.

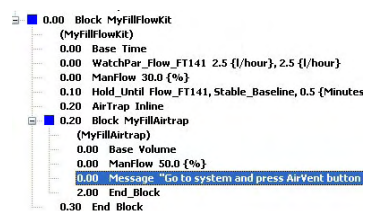

10.2.6 Block 5: Equilibration

The next block is for equilibrating the column:

Step	Action
------	--------

- | | |
|---|--|
| 1 | Create a new block named " MyEquilibration ", and set its base to Same as main (which in this case is column volumes). |
|---|--|

Note:

Selecting **Same as main** instead of **Column volumes**, ensures that the volume used is the same as that of the column you selected initially.

- | | |
|---|--|
| 2 | Set a pressure alarm at 2 bar by inserting the instruction Alarm_Delta_PT111_PT112 at 0 column volumes. Make sure the alarm is Enabled . |
|---|--|

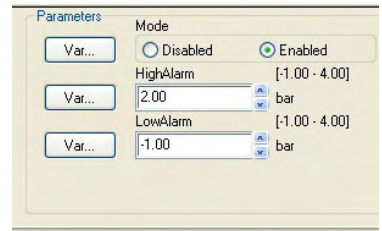

- | | |
|---|--|
| 3 | Add a Column instruction and set the column Inline . |
|---|--|

- | | |
|---|--|
| 4 | Set a Flow instruction to 300 cm/h, by first selecting Linear flow to change unit and then typing 300. Insert the instruction at 0.0 column volumes. |
|---|--|

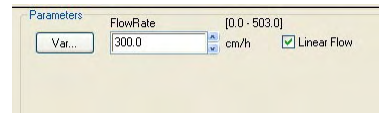

- | | |
|---|---|
| 5 | Set End_Block to 3.00, which means that the equilibration will finish after 3 column volumes. To achieve reasonable equilibration at least 1.5 column volumes should be pumped through the column. |
|---|---|

In the text pane, the finished **MyEquilibration** block should look like that in the figure to the right.

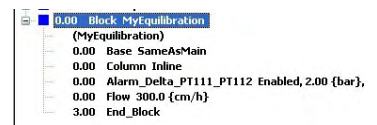

10.2.7 Block 6: Sample load

The block responsible for sample load has the sample volume as finishing criterion. Flow and valve positions (air trap inline and column inline) are maintained from the previous block and do not have to be redefined.

Step	Action
------	--------

- | | |
|---|---|
| 1 | Create a block named "MySampleLoad" and set its base to Volume . |
| 2 | Before starting sample injection, you need to auto-zero the UV sensor. This is done by inserting an AutoZero_UV_AT131 instruction (group Alarms&Mon). |
| 3 | At a volume of 2 liters, set the inlet to that which your sample container is connected by inserting an Inlet instruction and setting this to, for instance, Inlet1 . Insert also an Outlet instruction set to Outlet1 . Set both AirTrap and Column to ByPass . |
| 4 | Insert an InjectionMark (in group FlowPath) at 2 liters. This will set the time and volume to zero when the sample inlet valve is opened. |

- | | |
|---|---|
| 5 | In order to fill the flow path with sample liquid start a manual flow, which is stopped when the sample reaches the UV sensor (i.e., when the UV readings reach above a defined limit). The two instructions required for this are: |
|---|---|

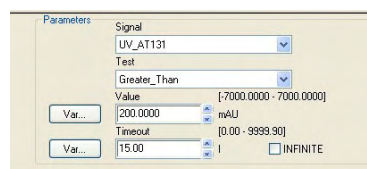

- **ManFlow** (in group **Pump**), which starts the flow and maintains it at a set level, in this case 50% (**ManFlow** is not controlled by the flow meter).
 - **Hold_Until** (in group **Watch**), which stops the flow when **UV_AT131** readings are **Greater_Than** a set limit, in this case 200 mAU. **Timeout** is set to, for instance, 15 liters.
- | | |
|---|--|
| 6 | When the flow kit is filled with sample liquid, the Column is again set to Inline and a Flow instruction set to, for instance 300 cm/h, is added. |
| 7 | Finally, set the End_Block instruction to equal the volume of your sample, for example 42.8 liters. |

The **MySampleLoad** block is now defined to run 42.8 liters of sample, after first having auto-zeroed UV, set an injection mark, and filled the flow kit with sample liquid.

```
0.00 Block MySampleLoad
(MySampleLoad)
0.00 Base Volume
1.00 AutoZero_UV_AT131
2.00 Inlet_Inlet1
2.00 Outlet_Outlet1
2.00 AirTrap Bypass
2.00 InjectionMark
2.00 ManFlow 50.0 (%)
2.00 Column Bypass
2.00 Hold_Until_UV_AT131_Greater_Than_200.0000
2.00 Column Inline
2.00 Flow 300.0 {cm/h}
42.80 End_Block
```

10 Creating a method

10.2 An example of using the Method Editor

10.2.8 Block 7: Washing unbound sample

10.2.8 Block 7: Washing unbound sample

After applying the sample you need to define instructions to wash out any unbound sample from the column.

Step	Action
1	Create a block named "MyWashOutSample", and set its Base to Time .
2	Select the inlet for the wash liquid by inserting an Inlet instruction at time 0.00. Set the inlet to, for instance, Inlet6 .
3	Insert a Hold_Until instruction that is triggered when UV readings are Less_Than a set limit (e.g., 100 mAU). At this point, the flow path is considered to be clean and the block will finish. The MyWashOutSample block first switches to the inlet of the washing liquid and then washes the flow path until the UV readings indicate it is clean.

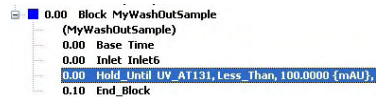

```
0.00 Block MyWashOutSample
(MyWashOutSample)
0.00 Base Time
0.00 Inlet Inlet6
0.00 Hold_Until UV_A1131, Less_Than, 100.0000 (mAU),
0.10 End_Block
```

10.2.9 Block 8: Elution

Similar to sample load and washing in previous blocks, elution is controlled by UV response. You thus need to define two watch blocks with UV-based criteria for starting and stopping the elution process. These blocks, in turn, refer to two external blocks, ***Fraction*** and ***Fraction_Stop***.

The ***Fraction*** block

Start by defining the external block ***Fraction***:

Step	Action
1	Create a block (in group <i>Frac</i>), name it “ <i>Fraction</i> ”, and set its <i>Base</i> to <i>Volume</i> (it does not matter where the block is created, it will be moved in a later later step).
2	Insert an <i>OutletFractions</i> instruction into the block, with the number of fractions set to 1 (in this example only one fraction is retrieved).
3	Set the volume to, for instance, 8 liters, and set the fraction outlet to <i>Outlet2</i> .

Once defining the Fractionation block is complete, right-click on it and select ***Delete*** in the menu shown. A dialog is displayed, in which you can choose to ***Delete*** or ***Move*** the block; select ***Move***. The block will be stored as ***Unused*** in the location you select, and will be available for insertion in any method.

The ***Fraction_Stop*** block

The procedure for creating the ***Fraction_Stop*** block is very similar to that of the ***Fraction*** block. There are two main differences: The ***Fraction_Stop*** block has ***SameAsMain*** (i.e., column volumes) as ***Base***, not ***Volume***, and the number of fractions in the ***OutletFractions*** instruction is set to 0 (zero). Setting the number of fractions to 0 means that fractionation will stop.

Store the ***Fraction_Stop*** block as ***Unused*** for the time being.

The Elution block

Now that you have defined and saved the **Fraction** and **Fraction_Stop** blocks, proceed by defining the elution block:

- | Step | Action |
|------|--|
| 1 | Create a block named “MyElution” and set its Base to Volume . |
| 2 | Insert an Inlet instruction at time 0.00. The instruction should be set to the inlet used for the elution liquid, for example Inlet5 (the outlet is left unchanged from previous block). |

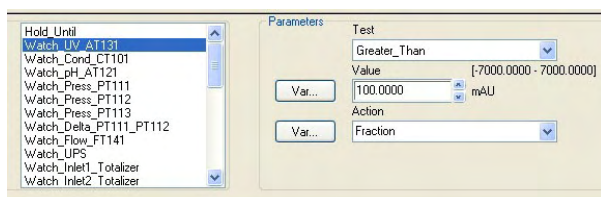

- | | |
|---|--|
| 3 | Create and insert a watch instruction, which starts fractionation when the UV level is above 100 mAU. This is done by selecting instruction Watch_UV_AT131 and, in the parameters area, setting the Test parameter to Greater_Than and the Value parameter to 100 mAU. In the popup menu under Action , select the Fraction block that you previously created. |
| 4 | Using the same procedure as in the previous step, create another watch instruction for stopping fractionation when UV goes below 90 mAU. Set the parameter Test to Less_Than and Value to 90 mAU, and select the previously created Fraction_Stop block, under Action . |

The **MyElution** block uses two watch instructions that trigger start and stop of the fractionation phase. Using external blocks like this is the recommended way of defining fractionation in the **Method Editor**.

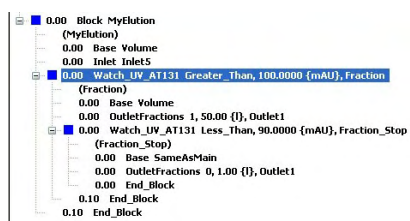

10210 Block 9: Regeneration

The last step for a complete chromatography cycle is to regenerate the column. This is done by defining a block with instructions for selecting inlet and outlet, and for setting the air trap and column inline.

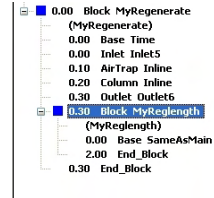

The finishing criterion is based on *SameAsMain* (i.e., column volumes) and is defined in a nested block. The procedure is very similar to that of defining a block for washing unbound sample (see [Section 10.2.8 Block 7: Washing unbound sample, on page 164](#)).

When, as in this case, a similar block already exists, time can be saved by copying the existing block, renaming it, and changing the parameter values as required.

10 Creating a method
10.2 An example of using the Method Editor
10.2.11 Saving the method

10211 Saving the method

Finish by saving your new method. **Select File:Save...** (or **File:Save As...**) in the **Method Editor** menu to bring up a **Save as...** dialog. In this dialog you specify the folder in which to save the method, and also the system and technique it is intended for.

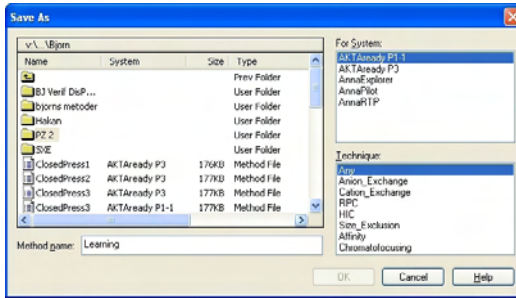

10.3 Creating a column efficiency test

General

Methods for testing of column efficiency can be created using the method wizard available in the **Method Editor**.

Opening the wizard

The wizard is opened from the UNICORN **Method Editor** menu by selecting **File: Method Wizard...**



Running the wizard

In the method wizard dialog, select column, and the inlets to be used for wash liquid and tracer solution. The method variables will be set according to the choice of column.

Leave the wizard dialog by pressing **Finish**.

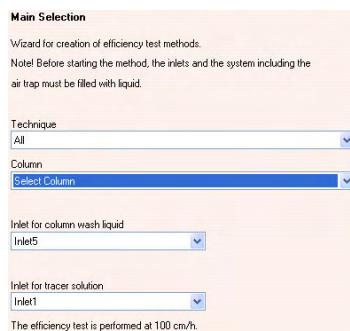

Editing the method

A method created with the method wizard can be later edited in the **Method Editor** via, for instance, the **Run Setup...** dialog. Open the dialog by selecting **View:Run Setup...** in the menu.

Variable value can be changed by selecting the **Variables** tab and changing the value of **CV_Equilibration**.

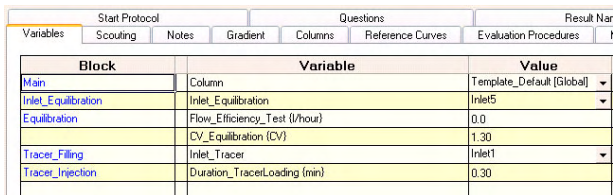

Block	Variable	Value
Main	Column	Template_Default (Global) ▾
Inlet_Equilibration	Inlet_Equilibration	Inlet5 ▾
Equilibration	Flow_Efficiency_Test (l/hour)	0.0
	CV_Equilibration (CV)	1.30
Tracer_Filling	Inlet_Tracer	Inlet1 ▾
Tracer_Injection	Duration_TracerLoading (min)	0.30

The default values of variables are:

- Flow velocity: 100 cm/h.
- Equilibration volume: 1.30 column volumes.
- Tracer volume loaded on the column: 2.5% of the column volume.

Note: For the method to work correctly, changing of the flow velocity requires changing of the tracer volume and vice versa.

Note: Only advanced users should change variables, shown in the detailed section (only displayed when **Show details** is checked).

11 Run a method

About this chapter

Running a method on ÄKTA ready is a largely automatic procedure. User interaction is mainly required in the preparation phase, which includes connecting the column and the required containers, and checking that all connections are correctly assigned and that flow kit type and volumes are correct.

Precautions



WARNING

Before attempting to perform any of the procedures described in this chapter, you must read and understand all contents of the corresponding section(s) in the [Section 2.1 Safety precautions, on page 16](#), as listed below:

- [General precautions, on page 16](#)
 - [Personal protection, on page 18](#)
 - [Operation, on page 21](#)
-

In this chapter

This chapter contains the following sections:

Section	See page
11.1 Final preparations before a run	172
11.2 Starting a run	176
11.3 Viewing and printing results	179
11.4 After the run	181

11 Run a method

11.1 Final preparations before a run

11.1 Final preparations before a run

Precautions



WARNING

Hazardous substances. When using hazardous chemicals, take all suitable protective measures, such as wearing protective glasses and gloves resistant to the substances used. Follow local and/or national regulations for safe operation and maintenance of the system.



WARNING

NaOH is corrosive and therefore dangerous to health. When using hazardous chemicals, avoid spillage and wear protective glasses and other suitable Personal Protective Equipment (PPE).



CAUTION

Do not use chemicals with temperatures above the specified limits.

Connect containers

Buffers

Connect the buffer inlet tubing to the appropriate buffer containers. Check that there are sufficient buffer volumes available.

Note: *Significant differences in the liquid level (height of elevation), in between connected inlet/outlet lines and containers, may cause unintended mixing in between the inlet/outlet lines if the valve switching time, (the time of overlap in open valves when switching inlets without pump stop), is selected too long.*

Samples

Connect the sample inlet tubing to the appropriate sample containers. Check that there is sufficient sample available.

Tip: *Use air sensors for optimal sample application.*

Fractionation

If fractionation is included in the method, connect the outlet tubing from the chosen outlet valves to appropriate fractionation containers.

Note: *Check that the fractionation containers will accept the volumes diverted to them during the run.*

Waste

Connect the waste tubing to a waste container. Check that the waste container is not full and will accept the volume diverted to it during the run.

Set valve switch time for inlet and outlet valves

The UNICORN control strategy features a short overlap in valve switching at the inlet and outlet valves. This overlap allows for continuous operation of the pump without the risk for blockage of the flow path due to a closed inlet or outlet manifold. When operating the system and switching from one inlet to another (from one outlet to another), the valve to be closed will be kept open for the period of a defined switch time after opening up the next valve. A minimum switch time of 0.1 seconds is required to account for possible delays in the execution of instructions of the system control and to eliminate the risk for a blockage of the flow path, respectively.

The valve switch time between the inlet and outlet valve can be changed in UNICORN. It is recommended to keep the valve switch time as short as required for the operation.

Set valve switch time in UNICORN

The valve switch operation time is set in UNICORN under **System:Settings:Specials** in **Inletswitchtime _Outletswitchtime**. The time range is 0.0 to 5.0 seconds. Default is 1 second.

11 Run a method

11.1 Final preparations before a run

Eliminate switch time

If the simultaneous opening of two valves as described above needs to be avoided, valve switching may be performed sequentially by stopping the pump operation, closing the first valve and opening the second valve.

Follow the instruction below to eliminate the switch time.

Step	Action
------	--------

- | | |
|---|-------------------------------|
| 1 | Stop the system pump. |
| 2 | Close the valve to be closed. |
| 3 | Open the valve to be opened. |
| 4 | Start the system pump. |

Check column

Check that the correct column is used and that the column tubing is fitted correctly.

Check that the column has been equilibrated (if this is not included in the method).

Check flow kit

Check that the flow kit is of the same type as that entered under **Administration:System setup** in UNICORN Manager (see [Before starting, on page 87](#)).

Calibrate flow meter

It is recommended that the flow meter is always calibrated when the flow kit has been changed.

Note: *The flow meter must be calibrated when changing to a different size flow kit.*

To calibrate the flow meter, fill the flow kit with water. Perform the calibration as outlined in [Calibrating flow meter, on page 188](#).

Prime the system

Before starting a run, make sure that the flow path, including hoses to inlet containers, are filled with liquid and that no air bubbles remain in the system.

The air trap can only remove small amounts of air. If air reaches the flow meter during a run, the alarm "Uncertain flow" will be displayed and the system will enter pause mode.

Priming should be done for each inlet, starting with inlet 1. Use the **ManFlow** command to control the pump during priming.

11.2 Starting a run

General

Starting a run is done from UNICORN, after first having checked that all inlets and outlets are correctly assigned, and that the volumes of inlet and outlet containers are correct.

Starting

Step	Action
------	--------

1	In the System Control module, select Run in the File menu.
---	---

2	Select the method to start. Click OK .
---	---

A Start Protocol is displayed, consisting of a number of dialog boxes. On the **Variables** page, it is possible to fine-tune the method before proceeding. Checking the **Show details** box will display more detailed information.

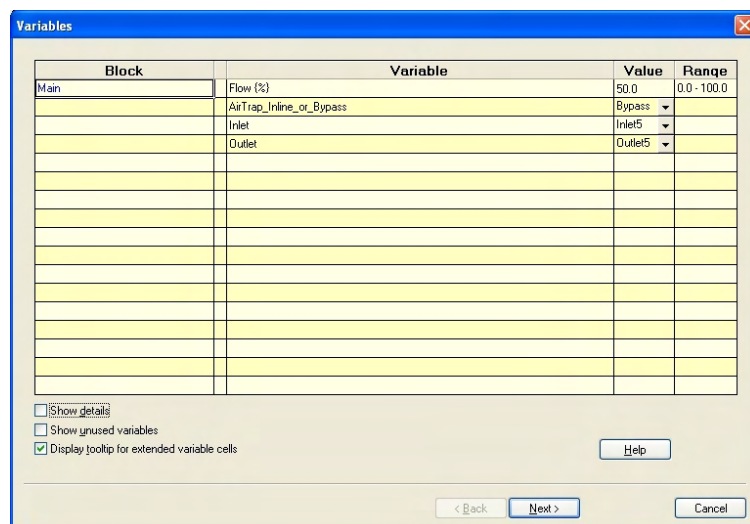

3	Check that the sample volume is correct.
---	--

4	Click Next or Back to navigate through the dialog panels, adding the information required as well as your own comments.
---	---

5	Click the START button in the Result Name dialog box. This will initiate the method run.
---	--

Monitoring

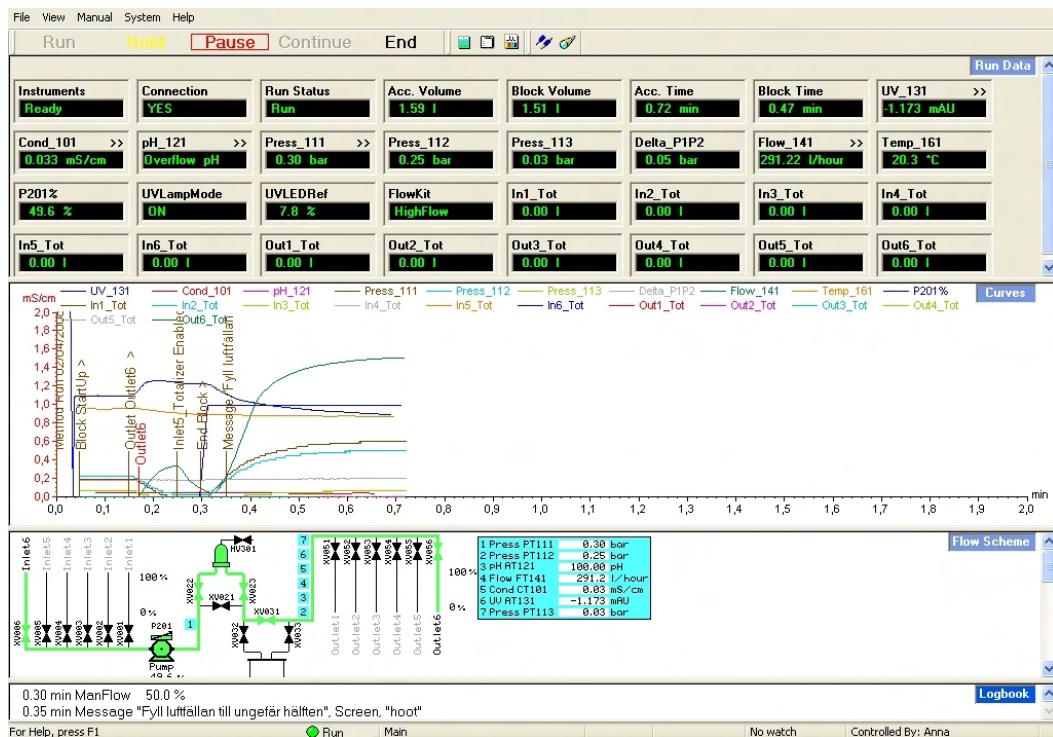

The progress of the run can be viewed in detail in the UNICORN **System Control** module.

Up to four different panels can simultaneously display different aspects of the run. To customize content and layout of a panel, right-click in it and select **Properties...** from the menu displayed. By selecting **Documentation: Run notes**, it is possible to add notes during a run. Entered notes will be included in the results.

More information regarding the monitoring possibilities that the UNICORN user interface offers is available in the *UNICORN User Manual*.

Ending

Normal completion

If no unexpected events occur during the run, UNICORN enters **END** state at method completion without need for user interaction.

End before method has finished

To end the run before the method has finished, click on the **End** button at the top of the **Control module** window.

This will produce a confirmation dialog. Click **OK** in the dialog to end the run, or click **Cancel** to keep running.

In the dialog, you can choose to save the (partial) results from the run so far. If the run is part of a scouting run, you are also given the choice of ending this. (If you do not, the next run will start automatically.)

Emergency stop



In case of emergency, stop the run by pressing the **EMERGENCY STOP** button. This will immediately stop the pump and close all inlet and outlet valves.

To restart the system after an emergency stop, turn the **EMERGENCY STOP** button to release it, and press the **PAUSE/CONTINUE** button.

11.3 Viewing and printing results

General

Results from a run are viewed in, and printed from, the UNICORN Evaluation module.

Viewing results

- | Step | Action |
|------|---|
| 1 | Locate the result file in the Files panel to the left in the Evaluation module. |
| 2 | Double-click on the file. The result file opens in a Chromatogram panel. |

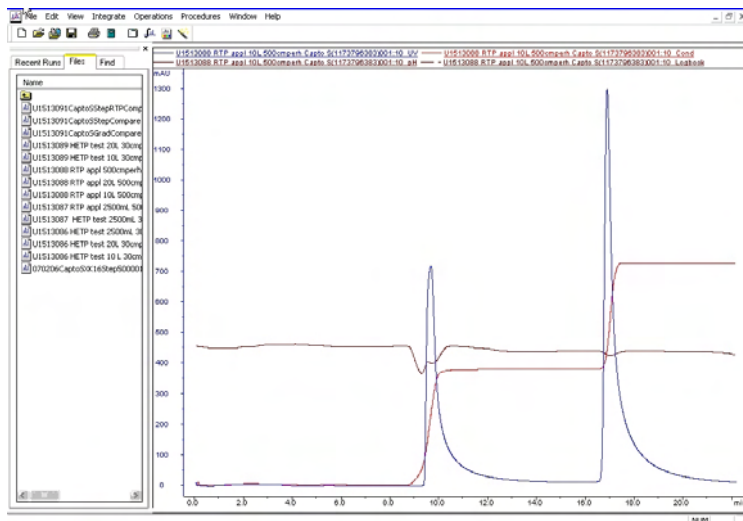

- | | |
|---|--|
| 3 | To change the layout of the Chromatogram panel, right-click and select Properties... . Select which curves to display by marking them in the Curve panel. Click OK . |
|---|--|

Refer to the UNICORN manuals for more information about viewing results and customizing layout.

Printing results

- | Step | Action |
|------|---|
| 1 | Open the chromatogram you want to print in the Evaluation module. |
| 2 | Select Print from the File menu. |
| 3 | In the Print Chromatograms dialog, select print format and layout options. |

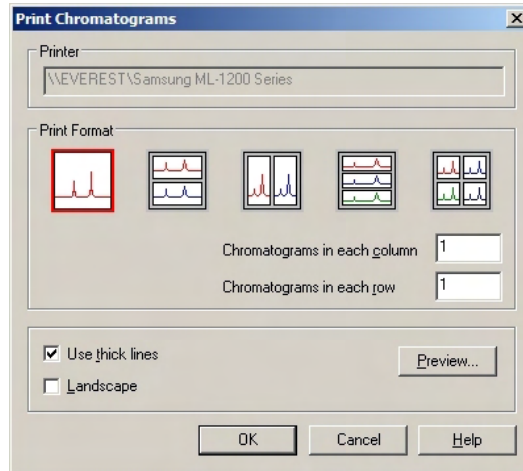

- | | |
|---|---|
| 4 | Click Preview . |
| 5 | In the Customise Report window, verify that the layout is correct. |
| 6 | Click Exit to return to the Print Chromatograms dialog. |
| 7 | Click OK . |

Refer to the *UNICORN User Manual* for more information about printing results.

11.4 After the run

General

If flow kit and column should be disposed of, this must be done in accordance with local regulations. Preparing the flow kit and column for disposal involves washing the flow kit and column, draining any liquid from them, and remounting the protective caps they were delivered with. Disconnect the pH electrode when the run is completed.

Disposing of flow kit and column



WARNING

Hazardous chemicals during run. When using hazardous chemicals, run **System CIP** and **Column CIP** to flush the entire system tubing with distilled water, before service and maintenance.

If the flow kit and column are to be dismantled and disposed of, proceed as follows:

Step	Action
1	While still mounted on the system cabinet, wash the flow kit and column with water. This is done by connecting water to one or more of the inlets and running a washing method from the ÄKTA ready.
2	Fill the flow kit and column with air by pumping air from an empty inlet.
	Note: <i>Use ManFlow when filling the system with air. The flow meter, which is used to control the pump, does not work with air in the system.</i>
3	Disconnect all inlet and outlet containers, and the column, and put back the protective caps delivered with the flow kit (the caps that were removed when mounting the flow kit).
4	Put the welded tubing ends back on the column's inlet and outlet.
5	Open all valves by turning the Installation switch to the FLOW KIT INSTALL position.
6	Remove all flow kit sensors from their holders/connectors. Wipe clean the contact surfaces of the flow cell connectors.
7	Open all manual valve locks by turning the black handles 180 degrees.

11 Run a method

11.4 After the run

Step	Action
8	Remove the pump lid.
9	Lift off the (still assembled) flow kit starting with the inlet and outlet manifolds.
10	If required, autoclave the flow kit (contained in, for example, an autoclave bag). Remove the protective caps before autoclaving.
11	Dispose of the empty flow kit and column in accordance with local regulations. Also consult the instructions in the column documentation.

12 Maintenance

About this chapter

ÄKTA ready uses ReadyToProcess flow kits. Maintenance tasks performed by the user are therefore few and simple. Regular maintenance is, however, important for safe and trouble-free operation of the ÄKTA ready. This chapter provides instructions for maintenance by the user and for replacing spare parts. Preventive maintenance should be performed on a yearly basis by qualified service personnel authorized by GE Healthcare. Contact your GE Healthcare representative for more service information.

Precautions



WARNING

Before attempting to perform any of the procedures described in this chapter, you must read and understand all contents of the corresponding section(s) in the [Section 2.1 Safety precautions, on page 16](#), as listed below:

- [General precautions, on page 16](#)
- [Flammable liquids and explosive environment, on page 17](#)
- [Personal protection, on page 18](#)
- [Operation, on page 21](#)
- [Maintenance, on page 25](#)



WARNING

Only personnel authorized by GE Healthcare may perform service, installation, and maintenance of components inside the ÄKTA ready cabinet.



WARNING

Before inspecting and maintaining ÄKTA ready, shut down the system, depressurize it, and disconnect the utilities. If not, accidental pump start-up or unexpected pressure release may cause human injury.



WARNING

Hazardous chemicals during run. When using hazardous chemicals, run **System CIP** and **Column CIP** to flush the entire system tubing with distilled water, before service and maintenance.



WARNING

Disconnect power. Always disconnect power from the instrument before replacing fuses.



NOTICE

Disconnect power. To prevent equipment damage, always disconnect the power from ÄKTA ready before an instrument module is removed or installed, or a cable is connected or disconnected.

In this chapter

This chapter contains the following sections:

Section	See page
12.1 Daily maintenance	185
12.2 Yearly maintenance	188
12.3 Spare parts	194
12.4 Storage	195

12.1 Daily maintenance

General

Regular maintenance is important for safe and trouble-free operation of the ÄKTA ready. This section provides instructions for daily maintenance by the user. Daily maintenance mainly includes cleaning and calibration of the pH electrode.



WARNING

Electrical shock hazard. All repairs should be done by service personnel authorized by GE Healthcare. Do not open any covers or replace parts unless specifically stated in the user documentation.

Cleaning



CAUTION

In order to avoid contamination, make sure the system is thoroughly cleaned before changing the flow kit.



CAUTION

Connectors on the cabinet, such as connectors for pH, conductivity, network, etc., that are not used, should be plugged to prevent cleaning liquid from entering the connector.

For proper function, the system should be kept clean and dry:

- Chemical stains and dust are removed by wiping the outside surfaces of the cabinet and the pump with a clean tissue wetted with water. Water with weak detergent should be used for daily cleaning of the cabinet. 70% ethanol or 2-propanol (isopropanol) can be used for sanitization.
- If salt buffer is spilled at valves, rinse carefully with water to remove salt crystals and wipe dry.
- Clean the system of infectious or aggressive fluids before service or maintenance. Make sure that the cleaning procedure flushes all possible flow paths in the system.
- If liquid should have accidentally spilled into the pump, clean the inside of the pump lid and the rollers with water. To avoid corrosion, make sure all surfaces are wiped dry. The interior of the pump is particularly sensitive to NaOH, which corrodes the aluminum.
- After cleaning, make sure there is no liquid left on the windows of the UV detector. If necessary, wipe the windows using soft, absorbent tissue.
- After cleaning flush the entire system with water or suitable liquid to remove the CIP solution. In some instances, you can use the system instrumentation to monitor the removal of cleaning solution.
- To avoid corrosion, wipe the cabinet dry after cleaning.

Note: *If a fuse repeatedly blows, shutdown the ÄKTA ready main switch and contact your local GE Healthcare representative.*

pH calibration

pH calibration should be done at least once a day. Suitable pH buffer solutions are required.

Note: *It is recommended to use fresh pH buffer solutions at every calibration.*

Step	Action
1	Two cups with the buffers representing the actual pH range are placed in the small holder located on the inside of the front cabinet door.
2	Release the pH cable from its storage position by unscrewing its lower end from the cabinet. Connect the pH electrode by screwing it onto the cable (see Mount the main part tubing, on page 95 step <i>pH electrode</i>).
3	Select System:Calibrate in ÄKTA ready System Control module.
4	Place the pH electrode in one of the buffers, enter the pH value for the buffer in the Reference value 1 field, wait for the value to stabilize, and press Read value 1 .
5	Rinse the electrode in distilled water and place it in the other buffer solution. Enter the pH value for the buffer in the Reference value 2 field, wait for the value to stabilize, and press Read value 2 .
6	Wait for response and, if electrode passed, press Close . Otherwise, press Close , refresh/change the pH electrode, and repeat the calibration.
7	Sanitize the pH electrode by spraying it with 70% ethanol.
8	Let the pH electrode dry and mount it as described in step 5 in Mount the main part tubing, on page 95 .

12.2 Yearly maintenance

About yearly maintenance

Preventive maintenance should be performed on a yearly basis by qualified service personnel authorized by GE Healthcare. Different service agreements are available. Contact your GE Healthcare representative for more information (contact information on back cover).

Although the user is not normally involved in long-term, periodic maintenance, there are a few tasks that can be performed by the user if so desired:

- Changing the air filter.
- Calibrating pressure sensors.

It is important that the user is always attentive about the status and operation of the equipment. The cause of any abnormal behavior or aberrant noise should be examined and removed. If the problem is non-trivial, contact your local GE Healthcare representative.

Sensors

Sensors are checked and, if necessary, changed by service personnel as part of the yearly service. Should a warning be displayed in UNICORN concerning one of the sensors, please contact GE Healthcare (contact information on back cover).

Calibrating flow meter

Flow readings that differ from zero under no flow conditions (e.g., when system is in its End state), and discrepancies between calculated and actual liquid consumption, indicate a poorly calibrated flow meter.

Flow meter calibration is a very simple procedure:

Step	Action
1	Make sure the flow kit is filled with liquid and that ÄKTA ready is in End mode.
2	Open the Calibration dialog under System in the UNICORN System control window, and select FlowCalib .
3	Start calibration by pressing Start Calibrate .

Applying lubricant to flow meter cell

If the warning "Fine tuning flow meter failed" is displayed in UNICORN, there may be insufficient lubricant between the flow meter cell and the transducers. Follow the instruction below to apply new lubricant.

Note: *It is safe to allow the ongoing run to finish before relubricating. Impact on flow measurements will be limited, with a maximum error less than 1%.*

Step	Action
------	--------

- | | |
|---|---|
| 1 | Pause the system and remove the transducers. |
| 2 | Wipe the transducer contact surfaces clean and apply a new layer of Vaseline on the surfaces. |
| 3 | Reconnect the transducers. |

Calibrating pressure sensors

If the readings from the pressure sensors deviate by more than ± 0.20 bar at any pressure, after autozero at atmospheric pressure, the sensors need to be calibrated. Calibration requires a special pressure calibration cell (article 28-9329-42 in [Section 14.4 Ordering information, on page 211](#)) and a suitable pump. The recommended pump is DPI 603 from GE Sensing.

Calibration is best performed with no flow kit mounted. Calibration includes the following steps:

Step	Action
------	--------

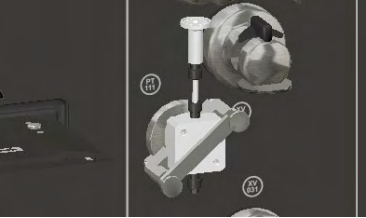
- | | | |
|---|--|--|
| 1 | Mount the calibration cell on pressure meter PT-111 (figure shows calibration cell with pump tubing removed). |  |
| 2 | Cycle the pressure cell a few times up to 5 bar until the reading at atmospheric pressure is stable. Select System:Calibrate in UNICORN System Control module. | |
| 3 | Open the calibration dialog in UNICORN. Select Monitor PT111 . Make sure that Reference value 1 is set to 0.0000 and that the cell is at atmospheric pressure (open the vent valve on the pump). Press the Read value 1 button. | |
| 4 | Close the venting valve on the pump and pump up to a pressure of 5 bar. Make sure that Reference value 2 is set to 5.0000 bar, and press Read value 2 . | |
| 5 | Release the pressure and verify that the pressure reading is 0.00 ± 0.01 bar at atmospheric pressure. | |

Step	Action
------	--------

6	Remove the calibration cell and verify that the reading now is -0.20 bar or less (if it is not, contact GE Healthcare).
---	---

7	PT-111 is now calibrated. Repeat the procedure for pressure sensors PT-112 and PT-113 .
---	--

Note that **PT-112** differs in the mounting of the calibration cell — an extra block must be inserted (arrow in figure) to compensate for the larger distance.

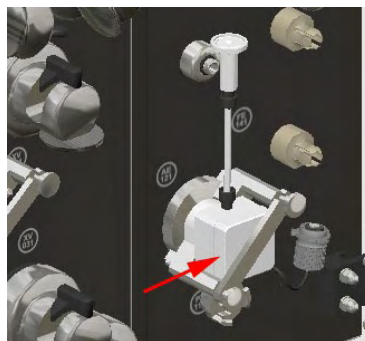

Calibrating conductivity sensor

Note: Calibration of the conductivity sensor is normally not necessary in UNICORN because a standard setting of the cell constant is used.

The procedure for calibrating the conductivity sensor is shown in the following steps:

Step	Action
------	--------

1	Prepare a calibration solution of 1.00 M NaCl, 58.44 g/1000 ml. Let the solution reach room temperature. This is important for exact measurements.
---	--

2	Set temperature compensation factor (CompFactor) to zero. CompFactor is found under System:Settings...:Monitors .
---	--

3	Fill the cell completely with the calibration solution by pumping at least 15 ml through the cell using a syringe.
---	--

Step **Action**

- 4 When finished, wait for 15 minutes until the temperature is constant in the range 20°C to 30°C.
- 5 In the **System Control** module, select **System:Calibrate...** Select **Cond_Cal** in the **Monitor** pop-up menu.
- 6 Read the conductivity value displayed under **Measured value** and compare it with the theoretical value from the graph opposite at the temperature of the calibration solution.
- If the displayed value and the theoretical value correspond, no further action is required.
 - If the values differ, proceed with step 7.
- 7 Enter the theoretical conductivity value according to the graph in the **Reference value 1** field.
- 8 Click the **Read value 1** button. The new cell constant is automatically calculated and updated.
-

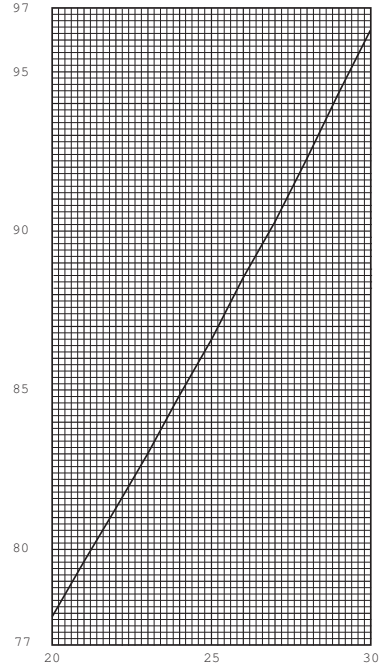

Testing the temperature sensor

The accuracy of the temperature sensor can be checked using a Temp test tool ([Section 14.4 Ordering information, on page 211](#)). Temperature testing is normally done once a year, during preventive maintenance.

Step	Action
1	Remove the pH electrode or pH electrode dummy from pressure cell pressure cell PT112 . Insert the Temp test tool (a in figure) and secure it in place with the pH electrode nut (b).
2	Insert a temperature probe, 3-6 mm in diameter (c), and tighten the top nut (d) on the Temp test tool.
3	Connect a calibrated temperature meter to the probe and start a manual flow of approximately 50% (for both high flow and low flow kit).
4	Read the temperature on the reference temperature meter and compare the reading to the temperature displayed in UNICORN (Temp_161). Calculate the deviation.
5	If the temperature deviation is greater than that given in the specification (Section 14.4 Ordering information, on page 211), contact you local GE representative.

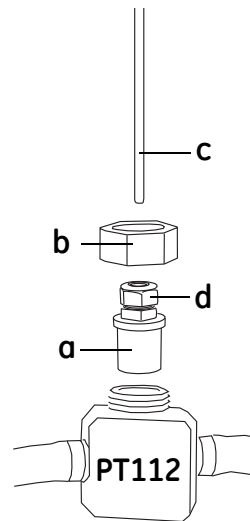

Air filter

The air filter is normally checked and, if necessary, changed during the yearly preventive maintenance. However, under extreme conditions the filter may become clogged. Therefore, check the condition of the air filter regularly. If the filter is dirty, change it as follows:

Step	Action
------	--------

- | | |
|---|--|
| 1 | Locate the filter beneath the cabinet front panel (arrow in figure). |
|---|--|

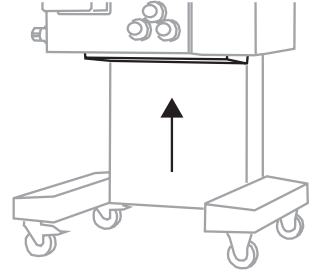

- | | |
|---|---|
| 2 | Remove the filter cover and filter by unscrewing the six knurled nuts (see lower figure). No tools should be necessary. |
|---|---|

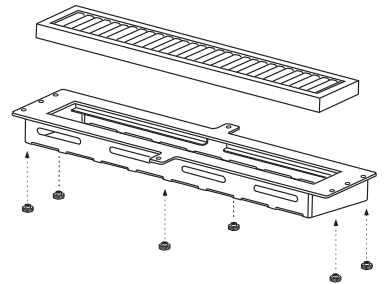

- | | |
|---|--|
| 3 | Wipe clean the bottom surface of the cabinet and the filter cover. |
|---|--|

- | | |
|---|--|
| 4 | Place the new filter in the cover, and the gasket on top, and then re-mount the filter cover using the knurled nuts. Use finger force to tighten the nuts. |
|---|--|

Pump head

Be observant of any changes in the sound of the pump, or of vibrations, as these may indicate that the pump rotor needs to be replaced. Normally, the pump rotor is checked and replaced in connection with yearly maintenance.

12.3 Spare parts

General

Apart from the flow kits, ÄKTA ready has very few parts that a user may need to replace. Normally, parts are checked and, if necessary, replaced by service personnel during preventive maintenance. For a list of available accessories and spare parts see [Section 14.4 Ordering information, on page 211](#).

Replacing spare parts

Pressure cell holder kit

The latches and screws holding the pressure cells in place are available as spare parts in the form of a Pressure cell holder kit. When mounting a pressure cell holder, make sure to turn the latch so it does not interfere with other components when opened. Use only finger force to tighten the screws.

Air filter nuts and cover

The knurled nuts holding the air filter cover are mounted as described on [Air filter, on page 193](#).

Wheels

The wheels are screwed onto the system cabinet support from below. This requires that the cabinet is lifted slightly. Before attempting to replace a wheel, carefully read the instructions in the *UNICORN Installation Guide* concerning lifting and moving the system unit.

With the unit lifted, the four bolts holding the wheel can be loosened and the wheel removed. Mount the new wheel using the same bolts.

Pump lid

See instructions in [Remove the pump lid, on page 90](#) regarding mounting of a new pump lid.

12.4 Storage

If the system is not used for a longer time period (more than a few days):

- Remove the flow kit (see [Section 11.4 After the run, on page 181](#)).
- Clean the cabinet (this chapter).
- If the system is moved, the system power and air supply should be switched off.

Note: *Although the system can be stored at temperatures between -25°C and +60°C, room temperature is preferable.*

Flow kits should not be stored at temperatures below 5°C.



CAUTION

Do not leave a flow kit mounted on the system for an excessively long time. The tubing walls may stick together where the tubing is squeezed, possibly causing high pressure alarms when running the system.



NOTICE

Only use 0.5 M NaOH (or higher) in the flow kit for a maximum time of 2 hours. Flush the flow kit tubing with a suitable rinsing liquid to remove the NaOH.

13 Troubleshooting

About this chapter

This chapter provides required information to enable users and service personnel to identify and correct problems that may occur when operating ÄKTA ready.

Note that problems related to sensors and valves normally are revealed during the component test, which is discussed in [Chapter 8 Component test, on page 111](#). This chapter focuses on mechanical parts such as valves and the pump, and on problems caused by a failing power supply or pressurized air.

If the suggested actions in this guide do not solve the problem or if the problem is not covered by this guide, contact your GE Healthcare representative.

Precautions



WARNING

EXPLOSION HAZARD! Read and understand all precautions in the Safety instructions chapter regarding flammable liquids and explosive environment before proceeding with any actions or procedures described in this chapter.



WARNING

Before attempting to perform any of the procedures described in this chapter, you must read and understand all contents of the corresponding section(s) in the [Section 2.1 Safety precautions, on page 16](#), as listed below:

- [General precautions, on page 16](#)
 - [Personal protection, on page 18](#)
 - [Maintenance, on page 25](#)
-

System

Component	Problem	Corrective action
Computer	No system found when starting up UNICORN.	<ul style="list-style-type: none"> • Make sure the system is switched on. • Check communication cable and connectors. • If system is connected to a switch or hub, check that the extra cable (3 m) is connected in series with the long (10 m) cable. • Reboot PC: shut down Windows, switch off the system power switch, wait at least 5 sec, restart system. • Reboot system.
	<p>Communication failure during a run.</p> <p>Contact between computer and system is broken.</p>	<ul style="list-style-type: none"> • Make sure the system is switched on. Check network cables and connectors. • Reboot system and PC. <p>Note:</p> <p><i>The system will continue to run even if the connection to the computer is broken. Data are stored locally and are transferred to the computer as soon as communication is restored.</i></p>
Power	Power failure during a run	<p>Check circuit breaker, both in system and for external supply, as applicable.</p> <p>Note:</p> <p><i>If the power failure is local, affecting only the computer, the system will continue to run while locally storing the data. Stored data are transferred to the computer as soon as communication with the computer is restored.</i></p> <p>Note:</p> <p><i>If the power failure also affects the system, no data can be stored and the run will have to be restarted.</i></p>
Compressed air	Compressed air failure during a run. The alarm “No air supply to the system” is displayed and the system enters PAUSE mode.	<p>Insufficient air pressure caused by, for instance, malfunctioning air supply equipment or a leaking air hose.</p> <p>a) Rectify the air supply problem.</p> <p>b) Restart the run by pressing the PAUSE/-CONTINUE button.</p>

Component	Problem	Corrective action
Air in flow path	Air enters the flow path. The alarm "Uncertain flow" is displayed and the system enters PAUSE mode.	Air enters the flow path due to, for instance, damaged tubing or connector, dislocated TC gasket, or inlet hose not properly located in liquid. In rare cases, cavitation due to underpressure may be the cause for air in the flow path. Cavitation can be recognized by a hissing noise. Check for kinks on flow kit tubing. 1 Locate and rectify the problem. Check the flow path, including the inlet containers. 2 Remove any air in the flow path using the ManFlow command in UNICORN. 3 Restart the run by pressing the PAUSE/ CONTINUE button. Note: <i>Note that small amounts of air are handled by the air trap. Larger amounts, reaching the flow meter cell cause "Uncertain flow" alarm.</i>
Flow meter	Warning "Fine tuning flow meter failed" is displayed.	The warning message means that the inaccuracy of the flow meter is maximum 1% unit higher than specified. The lubricant between the flow meter cell and the transducers may be insufficient. Lubricate according to the instructions in Applying lubricant to flow meter cell, on page 189 .
Valves	Alarm " Valve error " is displayed.	A valve lock may be open. Check the valve locks. Close if necessary. Note: <i>Before attempting to close the manual valve lock, make sure the valve is in an open position.</i> If the " Valve error " alarm is accompanied by " No air supply to the system ", the alarm is caused by a compressed air failure (see above).

Component	Problem	Corrective action
Pump	Pump not working	<ul style="list-style-type: none"> • Emergency button has been pressed. • Pump lid not properly attached / secured. See Connect and mount the pump tubing, on page 93 for instructions. • No inlet or outlet valve open. Check method and valves. • Incorrect method. Check by entering Pump:ManFlow > 1%. • If none of the above, contact GE Healthcare service personnel.
	Little or no flow	<ul style="list-style-type: none"> • Check that connected inlet is actually used. • Inlet containers are placed too low relative to the pump. Check inlet containers. • No liquid is supplied to the pump. Check inlet containers. • Flow kit tubing is split or burst. Replace flow kit. • Kinks or blockages in the flow kit. Remount or replace flow kit. See Section 6.3 Mounting the flow kit, on page 86 for mounting instructions. • Pump rotor slipping on the drive shaft, contact GE Healthcare service personnel.
	Pulsation of liquid in flow kit	Liquid too viscous and/or pump speed too slow. Check that viscosity of liquid is within specified range (see Section 14.1 Specifications, on page 202). Increase pump speed.
	Too high outlet pressure	<ul style="list-style-type: none"> • Check that connected outlet is actually used. • Check that the outlet is not plugged. • Too small outlet tubing diameter. Change to a larger tubing. • Flow kit mounted on system for too long, causing the inner walls of the tubing to stick together. Replace the flow kit.

Component	Problem	Corrective action
Flow kit	Excessive pressure	<p>Excessive pressure may damage the flow kit. If excessive pressure is detected and the air trap is in line, press the AIR VENT button on the system cabinet to reduce the pressure.</p> <p>If excessive pressure is detected when the air trap is bypassed, perform the following steps:</p> <ol style="list-style-type: none"> 1 In UNICORN, set Manual Flow to 0, and set the air-trap in line. 2 Press CONTINUE (in UNICORN, or on the system cabinet). 3 Press the AIR VENT button on the system cabinet.
	Drifting UV signal UV signal does not return to zero UV absorption values > 5 AU, even without flow kit installed	<p>Condensation of moisture on the flow cell window. The process liquid is too cold, must not be lower than 10°C from ambient temperature.</p> <p>Stray light calibration performed without cell. Install a flow kit and do a stray light calibration according to the instruction Manual calibration of UV stray light, on page 149.</p>

14 Reference information

About this chapter

This chapter provides reference information that may become useful when installing, operating, maintaining and troubleshooting ÄKTA ready. It also contains ordering information.

In this chapter

This chapter contains the following sections:

Section	See page
14.1 Specifications	202
14.2 Process wetted materials	206
14.3 Chemical resistance	208
14.4 Ordering information	211
14.5 PID control	215
14.6 Checklists	217
14.7 More information	222

14.1 Specifications

General specifications

Property	ÄKTA ready	ÄKTA ready gradient
Dimensions (width × depth × height)	100 × 80 × 165 cm	116 × 80 × 165 cm
Weight	230 kg	250 kg
Control system	UNICORN v 5.11 or higher	UNICORN v 5.11 or higher
AC voltage	1 × 100/120/200-208/220-230/240 V, ± 10%	1 × 100/120/200-208/220-230/240 V, ± 10%
Frequency	50/60Hz	50/60Hz
Max. power consumption	1 kVA	1 kVA
Ingress protection	IP45, pump IP25	IP45, pump IP25
Compressed air interface	5.5 to 10 bar, 50 NI/min, oil- and particle-free	5.5 to 10 bar, 50 NI/min, oil- and particle-free

Recommended operating conditions

Property	Value
Ambient temperature	2°C to 30°C
Liquid temperature	2°C to 40°C
Fluid density	950 to 1050 kg/m ³
Fluid viscosity	1.0 to 1.3x water viscosity at actual temperature, max. 2.5 cP

System capacity

Property	ÄKTA ready Low Flow Kit	ÄKTA ready High Flow Kit
Volumetric flow rates	3 to 175 l/h	7.5 to 510 l/h
Pump speed	225 rpm (100%)	340 rpm (100%)
Max. pressure, peristaltic pump	≥ 4.0 bar	≥ 4.0 bar

ÄKTA ready flow kit specifications

	ÄKTA ready Low Flow Kit	ÄKTA ready High Flow Kit
Tubing diameter (i.d.)	6.4 mm = 1/4"	9.5 mm = 3/8"
Inlet manifold diameter (i.d.)	9.5 mm = 3/8"	12.7 mm = 1/2"
Pump tubing diameter (i.d.)	8 mm	12 mm
Flow rate range	3 to 175 l/h	7.5 to 510 l/h
Total volume	0.762 l	2.145 l
Air trap volume	0.502 l	1.619 l
Connectors, type / size	TC 25	TC 25
No. of inlets / outlets	6/6	6/6
Max. pump speed	225 rpm	340 rpm
Pressure rating	<ul style="list-style-type: none"> • 0.6 bar (low pressure inlet manifold) • 5.0 bar (high pressure flow path, upstream of column) • 2.0 bar (high pressure flow path, downstream of column) • 0.95 bar (low pressure outlet manifold) 	

ÄKTA ready gradient section specifications

	ÄKTA ready Low Flow Kit	ÄKTA ready High Flow Kit
Tubing diameter (i.d)	6.4 mm = 1/4"	9.5 mm = 3/8"
Pump tubing diameter (i.d)	8 mm	12 mm
Flow rate range	3 to 175 l/h	7.5 to 510 l/h
Total volume	0.055 l	0.116 l
Connector (i.d)	TC 25	TC 25
Ambient temperature	2°C to 30°C	2°C to 30°C
Liquid temperature	2°C to 40°C	2°C to 40°C
Estimated shelf life	3 years	3 years
Maximum operating pressure	5 bar g (72.5 psi, 0.5 MPa)	5 bar g (72.5 psi, 0.5 MPa)

Sensor specifications

Sensor	Range	Acceptance range	Max. measurement error ¹
Pressure	-1 to 10 bar g	0 to 5 bar g	±0.20 bar g
Flow (High Flow Kit) ²	0 to 510 l/h	7.5 to 510 l/h	±5% actual value at flow ≥ 40 l/h ³ ±10% actual value at flow < 40 l/h ³
Flow (Low Flow Kit) ²	0 to 175 l/h	3 to 175 l/h	±5% actual value at flow ≥ 20 l/h ³ ±10% actual value at flow < 20 l/h ³
Conductivity ⁴	0 to 199.99 mS/cm	0 to 150 mS/cm	±5% full scale ⁵
pH ⁶	pH 0 to 14	pH 2 to 12	±0.2 pH at calibration temperature Drift: ±0.025 pH units/h (20°C, pH 4) Flow rate sensitivity: ±0.1 pH unit
UV	-7 to 7 AU	0.01 to 1.0 AU	Deviation from linearity ±5% ^{3,7,8}
Temperature ⁶	0 to 47°C	2°C to 40°C	±3°C ³

- 1 max. error, valid within acceptance range under operation conditions.
- 2 Flow meter cells for High Flow Kit and Low Flow Kit are designed with different flow path geometries
- 3 Valid for max. temperature difference of 10 °C between liquid and ambient temperature.
- 4 Temperature compensation optional. The standard setting of the cell constant for the sensor is 12.5 cm⁻¹ and is not to be changed when replacing flow kits.
- 5 Valid at actual temperature (no temperature compensation).
- 6 Temperature compensation not available.
- 7 Valid with ferric sulphate in 0.1 M sulphuric acid.
- 8 Cell length 1.8 mm ±0.2 mm.

14.2 Process wetted materials

Materials used

The materials used in the manufacturing of ÄKTA ready have been chosen for their biological and chemical compatibility with the solvents used during operation. The system has also been designed to comply with the varying hygienic requirements at the different stages of development and production. The flow kit tubing has been treated with gamma radiation, except for the pump tubing, which has been autoclaved (the pH electrode has not been treated).

List of wetted materials

Component	Materials
Tubing	Silicone, platinum cured, reinforced tubing in high pressure flow path
Pump tubing	Composite of expanded Polytetrafluoroethylene (PTFE) and platinum cured silicone
Connectors	Polypropylene (PP), polyether ether ketone (PEEK)
Flow meter body	Polymethylpentene (TPX)
Air trap	Polyamide (PA), transparent; Polypropylene (PP)
pH electrode	Polyoxymethylene (POM), ceramics (junction), glass
pH electrode dummy	Polypropylene (PP)
Conductivity cell	Polypropylene (PP), titanium
UV cell	Polypropylene (PP)
Sealing materials	Ethylene propylene diene monomer (EPDM); fluoroelastomer (FKM); thermoplastic elastomer (TPE)

Pretreatment of flow kits (wetted components)

- Assembly of cleaned parts in ISO 8 clean room.
 - Complete flow kit is gamma irradiated with 25 to 40 kGy, except for pump tubing and pH electrode.
 - StaPure™ pump tubing is autoclaved.
 - Gradient flow section tubing is autoclaved.
-

Material certificates (wetted components)

- CFR 177
 - USP VI
 - Animal free origin, alt. EMEA/410/01 compliant
-

14.3 Chemical resistance

External surfaces, cabinet

- Water with weak detergent should be used for daily cleaning of the cabinet.
 - 70% ethanol or 2-propanol (Isopropanol) can be used for sanitization.
-

Wetted parts

You must consider the compatibility of the wetted parts and your process chemicals so that no negative interaction takes place. Also ensure that your process chemicals do not damage the system components, compromising the safety of the system.

Contact your local GE Healthcare representative if you are not sure of the compatibility of your chemicals.

ÄKTA ready flow paths are resistant to chemical agents used in protein recovery, including buffer solutions for adsorption, elution and washing, and to solutions effective in cleaning and storage. The following table lists chemicals that may be used with ÄKTA ready. The concentrations listed are not normally exceeded during an operating cycle.

The information in the table below is valid for a **maximum exposure time of 48 hours**.

Note: *The table should be used only as a guide. The effects of a chemical will generally be more severe at higher temperatures.*

Note that the combined effects of agents have not been taken into account.

List of chemicals allowed

Chemical allowed	Concentration
Acetic acid	1 M
Acetone	2.5%
Aqueous buffers pH 2-12	<0.3 M
Arginine	2 M
Ammonium sulfate	4 M
Benzyl alcohol	2%
DTE/DTT	100 mM
EDTA	100 mM
Ethanol	20%
Formaldehyde	0.1%
Glycerol	10%
Glycine	2 M
Guanidine hydrochloride	6 M
Hydrochloric acid	0.1 M
Imidazole	1 M
Mercaptoethanol	20 mM
Pluronic™ F-68	1%
Polyethylene glycol, PEG 500	5%
Polyethylene glycol, PEG 1000	1%
Polyethylene glycol, PEG 5000	1%
Potassium phosphate	1 M
1-propanol	5%
2-propanol	30%
SDS	1%
Sodium acetate	1 M

14 Reference information

14.3 Chemical resistance

Chemical allowed	Concentration
Sodium chloride	4 M
Sodium citrate	1 M
Sodium sulfate	1 M
Sodium hydroxide	0.5 M (Maximum exposure time 2 hours)
Sorbitol	1 M
Sucrose	1 M
Triton™ X-100	1%
Tween™ 20	1%
Tween 80	1%
Urea	8 M

Note: *The percentage in the table is given in %(v/v).*

14.4 Ordering information

Introduction

This section contains ordering information for ÄKTA ready flow kits and ReadyToProcess columns, for ÄKTA ready accessories and spare parts, and for related literature.

ÄKTA ready flow kits

Product	Inner diameter (mm)	Code No
ÄKTA ready High Flow Kit	9.5	28-9301-83
ÄKTA ready Low Flow Kit	6.4	28-9301-82

ÄKTA ready gradient flow section

Product	Inner diameter (mm)	Code No
ÄKTA ready gradient High Flow section	9.5	29-0210-86
ÄKTA ready gradient Low Flow section	6.4	29-021-085

ÄKTA ready accessories, spare parts etc.

Product	Code No
pH electrode	18-1168-77
Column trolley	28-9318-80
Air filter	18-1169-58
Pump track assembly (pump lid)	28-9309-15
Pressure cell holder kit (latch and screws)	28-9298-87
Air Sensor ÄKTA ready	29-0038-79

14 Reference information

14.4 Ordering information

Product	Code No
Castor (wheel) without brake	28-9313-66
Castor (wheel) with brake	28-9313-77
TC Gasket 25/15 EPDM	44-5492-88
TC Clamp 25 SS	18-1001-31
TC Clamp 25 PP	44-0508-05

ReadyToProcess columns

Resin	Product	Size (l)	Code No
Capto adhere	RTP Capto adhere 1	1	28-9511-09
	RTP Capto adhere 2.5	2.5	28-9017-14
	RTP Capto adhere 10	10	28-9017-15
	RTP Capto adhere 20	20	28-9017-16
Capto MMC	RTP Capto MMC 1	1	28-9511-18
	RTP Capto MMC 2.5	2.5	28-9291-20
	RTP Capto MMC 10	10	28-9291-21
	RTP Capto MMC 20	20	28-9291-22
Capto Q	RTP Capto Q 1	1	28-9510-90
	RTP Capto Q 2.5	2.5	28-9017-23
	RTP Capto Q 10	10	28-9017-24
	RTP Capto Q 20	20	28-9017-25
Capto S	RTP Capto S 1	1	28-9510-93
	RTP Capto S 2.5	2.5	28-9017-29
	RTP Capto S 10	10	28-9017-30
	RTP Capto S 20	20	28-9017-31

Resin	Product	Size (l)	Code No
MabSelect	RTP MabSelect 1 NS	1	28-9511-28
	RTP MabSelect 2.5 NS	2.5	28-9415-22
	RTP MabSelect 10 NS	10	28-9415-23
	RTP MabSelect 20 NS	20	28-9415-24
MabSelect SuRe	RTP MabSelect SuRe 1	1	28-9511-10
	RTP MabSelect SuRe 2.5	2.5	28-9017-17
	RTP MabSelect SuRe 10	10	28-9017-18
	RTP MabSelect SuRe 20	20	28-9017-19
Phenyl Sepharose FF (low sub)	RTP Phenyl Sepharose 6 FF (low sub) 1	1	28-9511-11
	RTP Phenyl Sepharose 6 FF (low sub) 2.5	2.5	28-9017-35
	RTP Phenyl Sepharose 6 FF (low sub) 10	10	28-9017-36
	RTP Phenyl Sepharose 6 FF (low sub) 20	20	28-9017-37
Phenyl Sepharose 6 FF (high sub)	RTP Phenyl Sepharose 6 FF (high sub) 1	1	28-9511-97
	RTP Phenyl Sepharose 6 FF (high sub) 2.5	2.5	28-9291-08
	RTP Phenyl Sepharose 6 FF (high sub) 10	10	28-9291-09
	RTP Phenyl Sepharose 6 FF (high sub) 20	20	28-9291-10
CM Sepharose FF	RTP CM Sepharose FF 1	1	28-9512-08
	RTP CM Sepharose FF 2.5	2.5	28-9291-17
	RTP CM Sepharose FF 10	10	28-9291-18
	RTP CM Sepharose FF 20	20	28-9291-19
DEAE Sepharose FF (6FF)	RTP DEAE Sepharose FF 1	1	28-9511-26
	RTP DEAE Sepharose FF 2.5	2.5	28-9291-14
	RTP DEAE Sepharose FF 10	10	28-9291-15
	RTP DEAE Sepharose FF 20	20	28-9291-16

14 Reference information

14.4 Ordering information

Resin	Product	Size (l)	Code No
Q Sepharose FF (6FF)	RTP Q Sepharose FF 1	1	28-9511-25
	RTP Q Sepharose FF 2.5	2.5	28-9290-76
	RTP Q Sepharose FF 10	10	28-9290-79
	RTP Q Sepharose FF 20	20	28-9290-82
SP Sepharose FF (6FF)	RTP SP Sepharose FF 1	1	28-9510-97
	RTP SP Sepharose FF 2.5	2.5	28-9291-05
	RTP SP Sepharose FF 10	10	28-9291-06
	RTP SP Sepharose FF 20	20	28-9291-07

RTP columns packed with Capto and Sepharose 6FF media can be requested by GE Healthcare even if not listed in ordering list above.

ÄKTA ready IQ/OQ tools

Product	Code No
Low flow test kit ÄKTA ready	28-9336-80
UV Cond test tools ÄKTA ready	28-9336-88
Pressure calib tool ÄKTA ready	28-9329-42
Temp test tool ÄKTA ready	28-9388-64

14.5 PID control

Introduction

PID control (Proportional Integral Derivative control) is a well established and widely used method for feedback control of processes. This chapter contains a brief discussion about PID control, and how it is used in ÄKTA ready.

Principles

A PID controller uses the difference (error) between the actual (measured) value and a desired setpoint to compute the adjustment required in order to keep a process within defined boundaries.

A typical PID controller is tuned using the following three parameters:

- **P** — The weight of the current error. Proportional to the error.
 - **I** — The weight of the stationary, or long term change in the error. Reduces effects of error “trends”.
 - **D** — The weight of the current rate-of-change of the error. Reduces effects of short term error changes.
-

PID control in ÄKTA ready

In ÄKTA ready, PID control is used for controlling the pump speed based on flow velocity, as measured in the flow meter cell.

The method instruction **FlowTune** is used for setting the three PID parameters. The **FlowTune** instruction is available in group **Pump** in the **Method Editor:Instruction Box**. There are two sets of parameter fields under **FlowTune**, one for each flow kit size. Default values for the PID parameters are:

Column volume	P	I	D
1 l	0.3	25	0
2.5 l	0.3	25	0
10 l ¹	0.3	15	0
20 l ¹	0.5	10	0

¹ ÄKTA ready High Flow Kits should be used for columns of 10 l or more.

It is usually not necessary to tune the PID parameters — the default values can be used unchanged. If tuning is required, however, use large adjustments for the I-parameter. (To slow down control, double the I value, and to speed it up, set it to half the initial value.)

14.6 Checklists

Performed tasks checklist

Step	Check	Sign	Remark
1 Unpacking	Contents according to packing list?		
	No visible damage on the system?		
2 Installation, system unit	System unit positioned with sufficient surrounding space, and power switch and emergency stop easily accessible (see Section 4.5 Positioning the system, on page 71)?		
	Wheels of system unit locked (see Section 4.5 Positioning the system, on page 71)?		
	Connected to computer (see Computer, on page 74)?		
	Compressed air connected (see Compressed air, on page 72)?		
	Mains power correctly configured (see Power, on page 72) and cable connected to source?		

14 Reference information

14.6 Checklists

Step	Check	Sign	Remark
3 Installation, computer	UNICORN installed and working (see UNICORN documentation)?		
	Bar code scanner installed (see instructions in the scanner's Quick Start Guide)?		
	ÄKTA ready strategy software installed and verified (see UNICORN documentation)?		
4 Preparation, Installation test	Test fluids prepared.		
	Inlet/Outlet containers available?		
	Flow kit for testing available.		
5 Installation test	Performed installation test (details below)?		

Installation test checklist

Calibration, pressure sensors

Perform pressure sensor calibration as described in [Calibrating pressure sensors, on page 189](#).

Pressure sensor	Perform	Sign	Remark
PT-111	Calibration at 0 bar g		
	Calibration at 5 bar g		
PT-112	Calibration at 0 bar g		
	Calibration at 5 bar g		
PT-113	Calibration at 0 bar g		
	Calibration at 5 bar g		

Check pressure sensor calibration

In the record table below, enter the True pressure value (reference) and the corresponding Read value (computer run data).

Pressure sensor	Check	True value	Read value	Remark
PT-111	Calibration at 0 bar g			
	Calibration at 5 bar g			
PT-112	Calibration at 0 bar g			
	Calibration at 5 bar g			
PT-113	Calibration at 0 bar g			
	Calibration at 5 bar g			

Temperature sensor check

Verify that the temperature sensor is working and gives a realistic value. This can be done by filling a plastic test tube with tempered water and holding it in front of the temperature sensor. Then check that the temperature (**Temp_161**) in UNICORN is responding.

Component	Sign	Remark
TE-161		

14 Reference information

14.6 Checklists

Check function of valves

Perform a functional test of all valves in the system by manually switching each valve on/off in UNICORN. Airtrap valve **HV-301** is manually controlled with the **AIR VENT** button on the front of the system cabinet.

Check that the flow diagram in UNICORN is updated and that the valve is in its correct state. In the record table, mark checked function with "OK"/ "Not OK".

Valve	Open	Closed	Remark
XV-001			
XV-002			
XV-003			
XV-004			
XV-005			
XV-006			
XV-021			
XV-022			
XV-023			
XV-031			
XV-032			
XV-033			
XV-051			
XV-052			
XV-053			
XV-054			
XV-055			
XV-056			
HV-301			

pH calibration

Perform a pH calibration as described in [pH calibration, on page 187](#). In the table below, enter the recorded pH values after calibration.

Component	pH 4	pH 7	Remark
AE-121			

Installation test method performance

Perform a component test as described in [Chapter 8 Component test, on page 111](#). The test result (printed report) is attached to the ITR and filed in the customer log book.

Component	OK/ Not OK	Remark
UV		
Conductivity		
Flow		
Pressure sensors		

System serial number:

Installation performed by:

Date:

Installation accepted:

14.7 More information

Spare parts and accessories

Additional information regarding spare parts and accessories can be found in the system documentation. For lists of documents, see [Section 1.3 Associated documentation, on page 14](#).

Your local GE Healthcare representative will also be able to suggest recommended spare parts and accessories.

Remaining aspects

Regarding

- Service
- Method optimization
- Ordering information (first, see [Section 14.4 Ordering information, on page 211](#))
- Other issues not covered by this manual

Please contact your local GE Healthcare representative for advice.

Contact information is found on the back cover of this manual.

Training

GE Healthcare recommends that all new operators attend the training courses available from GE Healthcare. The courses will provide all information necessary for inexperienced operators to safely operate ÄKTA ready. Courses in the field of bioprocess development and manufacturing are available from GE Fast Trak™ Training & Education.

For more information about training, please contact your local GE Healthcare representative.

Index

A

- Accessories, 211, 222
- Accessory kit, 62
- Air sensor, 55
- ÄKTA ready
 - Areas of application, 40
 - Associated products, 40
 - Dimensions, 63, 202
 - Features, 40
 - Flow chart, 50
 - Included in the delivery, 62
 - Installation, 60
 - Intended use, 39
 - Layout, 41
 - Maintenance, 183
 - Run a method, 171
 - Specifications, 63, 202
 - Starting, 79
 - Unpacking instruction, 70
 - Weight, 63, 202
- ÄKTA ready gradient
 - Gradient flow section, 101
 - Gradient range, 101
 - Unpacking instruction, 70
 - Weight, 63
- Associated products, 40

B

- Barcode reader
 - installation, 78
- Breakpoint, method editor, 146

C

- Calibration
 - pH, checklist, 221
 - Pressure sensors, 219
 - Pressure sensors, checklist, 218
- CE
 - Conformity, 11
 - Marking, 12
- Center of gravity, 68
- Checklists, 218
- Chemical resistance, 208
- Chemicals, 210

Column

- Adding to column list, 141
- Installation, 125, 130
- Optional column rinsing, 140
- Optional column test, 137
- ReadyToProcess, 128
- Types, 127
- Components
 - Drawing, back, 46
 - Drawing, front, 43
- Component test, 111
 - Run a test, 112
 - Test report, 117
 - Troubleshooting, 120
- Compressed air
 - Connecting, 64
- Computer, 74
- Conductivity cell, 97
- Conductivity sensor, 56
- Connections, 72
- Creating a method, 142
- Customer I/O, 75

D

- Decontamination, 34
- Delivered items, 62
- Description, 38
- Disposal
 - General, 34
- Documentation
 - Generic, 14
 - Related literature, 14

E

- Emergency
 - Procedures, 30
 - Restarting the system, 33
 - Shutdown, 31
 - Stop, 31
- Equipment, 53
- Explosive environment, precautions, 17

F

- Flammable liquids, precautions, 17
- Flow chart, 50
- Flow kit
 - Alternative mounting procedure, 100
 - Attach main part tubing, 92
 - Before starting
 - Aseptic solution, 87
 - End caps, 87
 - Open the installation wizard, 88
 - pH calibration, 88
 - TC clamps, 87
 - Test liquids, 88
 - Components drawing, 47
 - Connect and mount pump tubing, 93
 - Finishing installation, 99
 - Flow rates, 203
 - Installation, 82
 - Labeling, 85
 - Mounting, 86
 - Mount inlet manifold, 92
 - Mount outlet tubing, 99
 - Open valve locks, 89
 - Pressure cell holders, 91
 - Pretreatment, 207
 - Remove pump lid, 90
 - Specifications, 203
 - Three parts, 83
 - Types, 84
 - Unpacking, 85
 - What is delivered, 85
- Flow kits
 - Associated products, 40
 - Ordering information, 211
- Flow meter
 - Disable warning, 150
- Flow meter cell, 55

G

- General precautions, 16
- Gradient flow section, 42, 103
 - Installation, 104
 - Ordering information, 211
 - Types, 104
- Gradient pump, 51, 102

- Calibration, 107

- Layout, 42

- Gravity, 68

I

- Installation, 60
 - Finishing, 76
 - Positioning, 71
- Installation test
 - Checklist, 221
- Installing and moving, precautions, 18
- Instructions, method editor, 146

L

- Labels
 - Safety labels, 29
 - System label, 27
- Layout, 41
- Layout gradient pump, 42
- Lifting, 67

M

- Maintenance
 - Daily, 185
 - Spare parts, 194
 - Yearly, 188
- Maintenance, precautions, 25
- Material compliance, 39
- Method editor
 - Buttons, 147
 - Undo function, 147
- Method Editor, 144
 - Blocks, 144
 - Instructions box, 146
 - Text pane, 146
- Method optimization, 222
- More information, 222

N

- Notes and tips, 10

O

- Operation, precautions, 21
- Ordering information, 211, 222
 - IQ/OQ tools, 214
 - ReadyToProcess, 213
 - Spare parts., 211

P

Parameters, method editor, 146
 Parts
 Drawing, 41
 Personal protection, 18
 pH
 Calibration checklist, 221
 pH electrode, 55, 98
 PID control, 215
 Pinch valves, 53
 Positioning the system, 71
 Pressure cells, 54

R

Reference information, 201
 Regulatory compliance, 13
 Restart after emergency, 33
 Run a method, 171

S

Safety labels, 29
 Safety notices, 9
 Safety precautions, 16
 Sensor
 Specifications, 205
 Service , 222
 Spare parts, 211, 222
 Specifications, 63, 202
 Starting the system, 79
 Storage, 195
 Stray light calibration, 112, 116
 System
 Capacity, 203
 System label, 27
 System setup, 87

T

Temperature
 Changes, 55
 Recommended operating conditions, 202
 Sensor, 55
 Sensors checklist, 219
 Training, 222
 Troubleshooting, 196
 Typographical conventions, 10

U

UNICORN
 Alarms, 59
 Column efficiency test, 169
 Control system, 57
 Creating a method, 142
 Overview, 57
 Prerequisite, 57
 Software modules, 58
 System networks, 57
 Warnings, 58
 Work flow, 58
 UV
 Stray light calibration, 148
 Troubleshooting , 200
 Component test, 123
 UV cell, 56
 Mounting, 98

V

Valve
 Check function, 220

W

Wetted materials, 206
 Wheels, 71

For local office contact information, visit
www.gelifesciences.com/contact

GE Healthcare Bio-Sciences AB

Björkgatan 30

751 84 Uppsala

Sweden

www.gelifesciences.com/readytoprocess

GE, imagination at work and GE monogram are trademarks of General Electric Company.

BioProcess, Capto, MabSelect, MabSelect SuRe, ReadyToProcess, Sepharose, UNICORN and AKTA are trademarks of GE Healthcare companies.

Microsoft and Windows are trademarks of Microsoft Corporation. Pluronic is a trademark of BASF SE.

StaPure is a trademark of Algatechnologies LTD.

TRI-Clamp is a trademark of Alfa Laval Corporate AB.

Triton is a trademark of Union Carbide Chemicals and Plastic Company Inc.

Tween is a trademark of Uniqema Americas LLC.

Vaseline is a trademark of Unilver N.V.

© 2009-2013 General Electric Company – All rights reserved.
First published Sep. 2009

All goods and services are sold subject to the terms and conditions of sale of the company within GE Healthcare which supplies them. A copy of these terms and conditions is available on request. Contact your local GE Healthcare representative for the most current information.

UNICORN: Any use of UNICORN is subject to GE Healthcare Standard Software End-User License Agreement for Life Sciences Software Products. A copy of this Standard Software End-User License Agreement is available on request.

GE Healthcare Europe GmbH
Munzinger Strasse 5, D-79111 Freiburg, Germany

GE Healthcare UK Limited
Amersham Place, Little Chalfont, Buckinghamshire, HP7 9NA, UK

GE Healthcare Bio-Sciences Corp.
800 Centennial Avenue, P.O. Box 1327, Piscataway, NJ 08855-1327, USA

GE Healthcare Japan Corporation
Sanken Bldg. 3-25-1, Hyakunincho Shinjuku-ku, Tokyo 169-0073, Japan

